

Panasonic

Personal Facsimile

Model No. **KX-F555**

OPERATING INSTRUCTIONS



Please read these Operating Instructions before using the unit.

*** FAX PAPER ***

98 foot roll of Panasonic super thermal paper

~ or ~

164 foot roll of standard thermal paper

(See page 59 for order numbers.)

Please read **IMPORTANT SAFETY INSTRUCTIONS** on page 58 before use. Read and understand all instructions.

Caution:

The Telephone Consumer Protection Act of 1991 makes it unlawful for any person to use a computer or other electronic device to send any message via a telephone facsimile machine unless such a message clearly contains in a margin on the top or bottom of at least the first sent page the following information:

- 1) Date and time of transmission; and,
- 2) Identification of either business, business entity or individual sending the message; and,
- 3) Telephone number of either the sending machine, business, business entity or individual.

In order to program this information into your facsimile machine, you must complete the steps on pages 30 to 31 in these Operating Instructions.

Important Phone Numbers

Authorized Service Center: 1-800-545-2672

Accessory Purchases: 1-800-332-5368

Technical Support: 1-800-HELP-FAX

Accessories

For recording paper replacement, see page 59.

Power cord
..... 1pc



(page 9)

Telephone line
cord 1pc



(page 9)

Paper stacker
..... 1pc

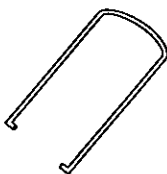

(page 8)

Recording
paper 1pc

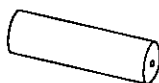

(page 8)

Handset* . . 1pc

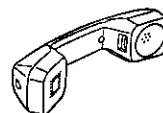

(page 9)

Handset cord
..... 1pc



(page 9)

*Illustrations of the handset in these operating instructions and the quick reference guides will vary from the actual product.

Ilustraciones del auricular en estas instrucciones de operacion y la guía de referencia rápida variarán del producto actual.

Any details given in these instructions are subject to change without notice.
The picture on the cover page will vary from the actual product.

Thank you for purchasing the Panasonic Personal Facsimile.

Features

General

- Desktop type
- LCD (Liquid Crystal Display) readout
- Automatic paper cutter
- Silent ring fax recognition system (page 23)
- Help function (see below)
- TAM (telephone answering machine) interface (page 18)
- Copier function (page 25)

Facsimile

- Automatic document feeder (up to 15 sheets)
- 64-level halftones
- Resolution: standard/fine/super fine/halftone (page 15)
- Delayed transmission (page 36)
- Paper save function (page 43)
- Overseas transmission mode (page 42)
- Remote fax receiving using an extension phone (page 37)
- Junk mail prohibitor (page 39)

Integrated telephone system

- One-touch dialer (10 phone numbers) (page 32)
- 22-station speed dialer (page 33)
- Hands-free speakerphone (page 12)
- Electronic telephone directory (page 34)

HELP function

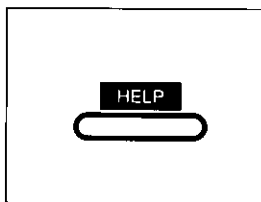

Use this function if the instructions are lost while using the unit. It will provide the user with instructions.

When the **HELP** button is pressed, the unit will print a quick reference.

Information:

When you use the unit with a telephone answering machine, transmit the FAX CORRESPONDENCE leaflet on page 63 to several of your associates. In this way, you can confirm that your facsimile unit and telephone answering machine will function correctly and inform them of the procedure for transmitting documents and/or recording voice-messages.

Table of Contents

1 Installation and Preparation

Location of Controls	6
Front view	6
Rear view	6
Control panel	7
Installing Your Unit	8
Installing the recording paper	8
Installing the paper stacker	8
Connections and dialing mode setting	9
Adjusting Volumes	10
Selecting the Receive Mode	11

2 Basic Instructions

Telephone

Making and Answering Voice Calls ..	12
Making voice calls	12
Making voice calls using automatic dialing ..	12
Redialing the last dialed number	13
Voice muting	13
Answering voice calls	13
Helpful hints for the speakerphone operation	13

Facsimile

Before Transmission	14
Acceptable documents	14
Loading documents	15
Setting resolution	15
Sending 16 or more sheets	15
Transmitting Documents	16
Transmitting documents manually	16
Transmitting documents with fewer procedures	16
Transmitting documents using automatic dialing	17
Receiving Documents and/or Voice Calls	18
Manual reception	18
Automatic reception	18
Receiving in the EXT. TAM mode	18
Connection	18
How to receive incoming calls in the EXT. TAM mode	19
Setting up the answering machine	20
Setting the remote TAM activation ID	20

Setting the silent detection	21
Notice when using with an answering machine	21
Receiving in the TEL/FAX mode	22
Setting the number of rings to answer in the TEL/FAX mode	23
Silent ring fax recognition system	23
Receiving in the FAX mode	24
Setting the number of rings in the FAX mode	24

Copier

Making a Copy	25
---------------------	----

3 Basic Settings

User Programmable Features	26
Programming feature table	26
How to enter letters and symbols	28
To enter characters	28
Special uses of the direct call station keys	29
Setting the date and time	30
Setting your logo	30
Setting your facsimile telephone number ..	31
Setting the transmission report printing	31

Storing Phone Numbers for

Automatic Dialing	32
Storing phone numbers for one-touch dialing	32
Storing phone numbers for speed dialing ..	33
To keep a phone number secret	33

4 Advanced Instructions

Electronic Telephone Directory	34
How to use the electronic telephone directory	34
Polling	35
Polling reception	35
Polling transmission (Polled)	35
Delayed Transmission	36
Remote Fax Receiving Using an Extension Phone	37
Using an extension phone	37
Changing the remote fax activation code ..	38

Junk Mail Prohibitor	39
Setting the junk mail prohibitor	39
Transmitting documents to your unit with the prohibitor ID	40
Special Settings	41
Logo print position	41
Overseas transmission mode	42
Paper save reception/copy	43
Extension copy	44
Original mode	45
Resetting the advanced features	45
Voice Contact	46
Initiating voice contact	46
Receiving a request for voice contact	46
TONE, FLASH and PAUSE Buttons .	47
TONE button	47
FLASH button	47
PAUSE button	47

5 Reports and Lists

Printing Reports and Lists	48
How to print each report/list	48
Sample reports and lists	49
Setting journal auto print	51

6 Troubleshooting and Maintenance

Troubleshooting	52
Error messages on the display	52
General corrective measures	53
Explanation of communication result on the report	54
Clearing a recording paper jam	55
Clearing a document jam	56
Adjusting the feeder pressure	56
Maintenance	57
Cleaning the document feeder unit	57
Cleaning the thermal head	57

7 General Information

Important Safety Instructions	58
Accessory Order Information	59
Specifications	59
FCC Information	60
Limited Warranty	61
Index	62
FAX CORRESPONDENCE	63
Speed dialer list	65
Service center directory	67

Location of Controls

Front view

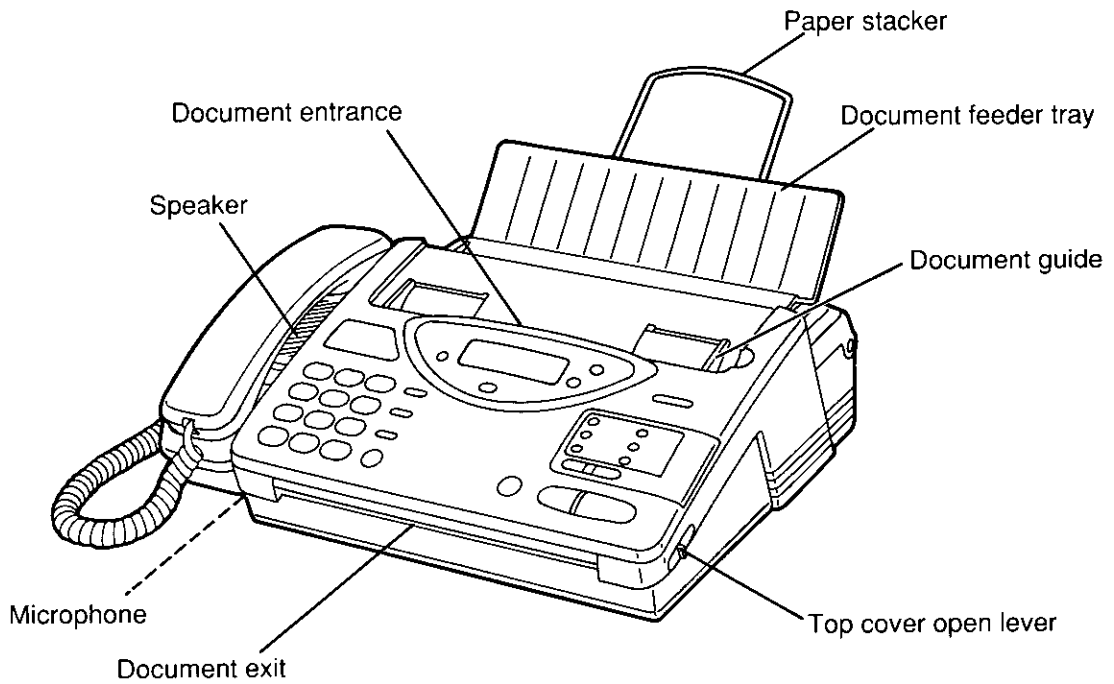

Rear view

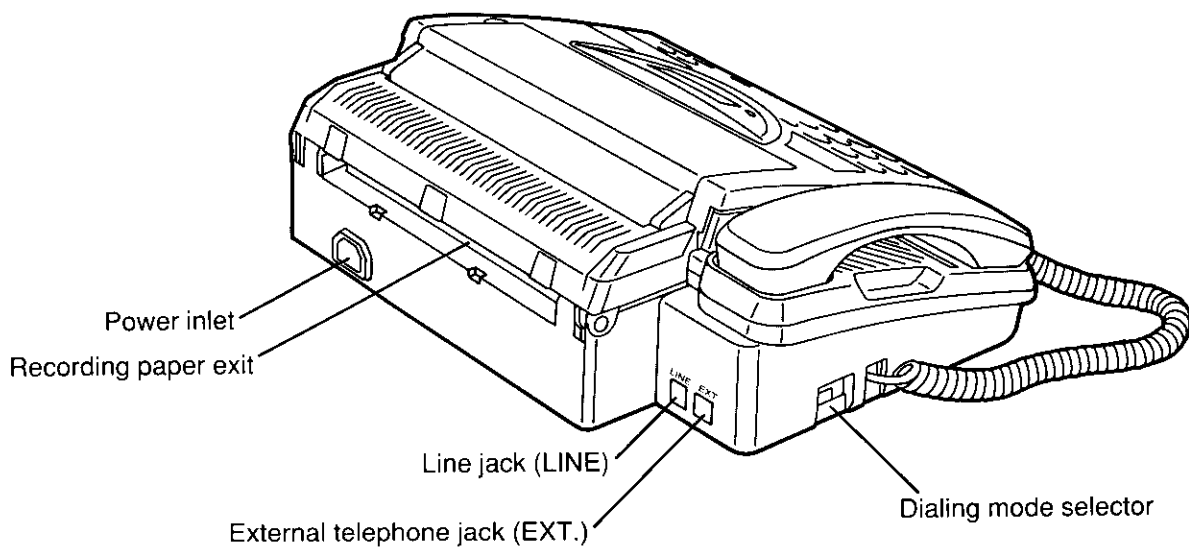

Control panel

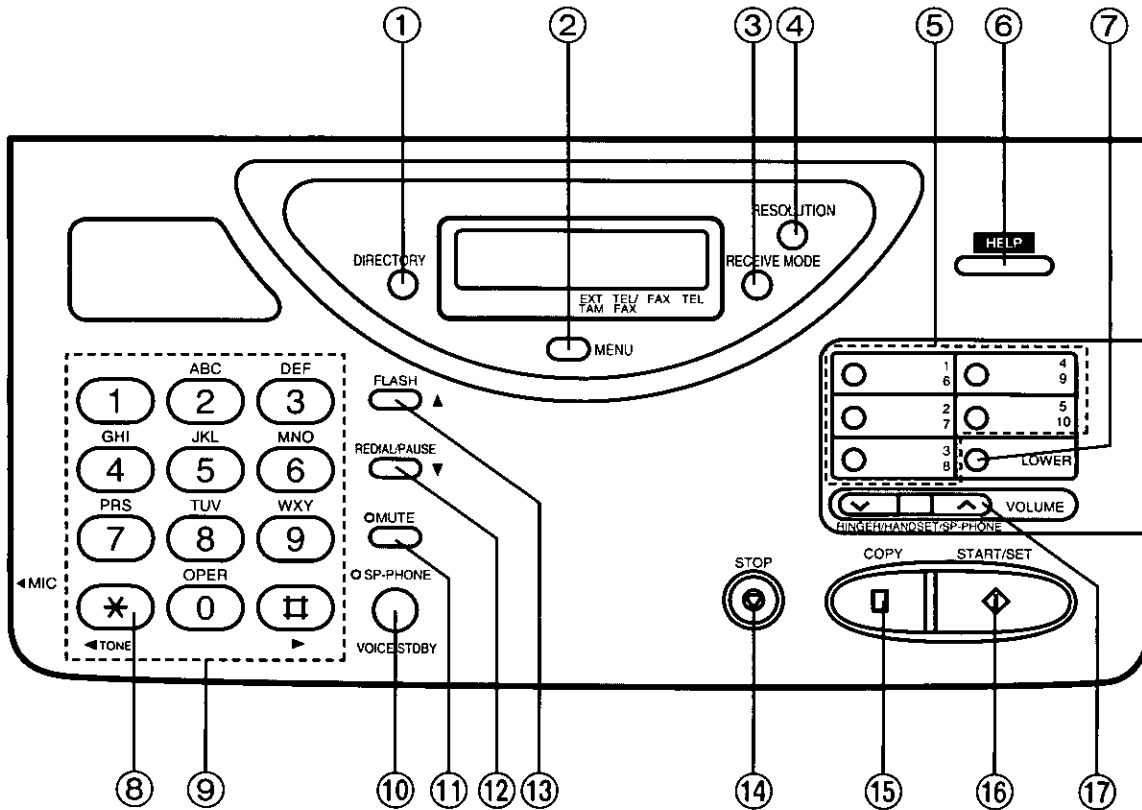

- ① **DIRECTORY button** (pages 12, 17 and 34)
Used for speed dialing. Also used for the electronic telephone directory.
- ② **MENU button**
Used to start and exit various programming.
- ③ **RECEIVE MODE button** (page 11)
Used to select the desired receiving mode.
- ④ **RESOLUTION button** (page 15)
Used to adjust scanning line density.
- ⑤ **Direct call station keys** (pages 12, 17 and 29)
Used for one-touch dialing. Also used as character keys when logo and station names are programmed.
- ⑥ **HELP button** (page 3)
Used to print an easy guide of operations.
- ⑦ **LOWER key** (pages 12, 17 and 32)
Used to access lower stations (6 to 10) for one-touch dialing.
- ⑧ **TONE button** (page 47)
Used to temporarily change the dialing mode from pulse to tone during a dialing operation.
- ⑨ **Dial keypad**
Used for dialing operation and parameter setting. Also used as character keys.
- ⑩ **SP-PHONE/VOICE STDBY button** (pages 12 and 46)
Used for on-hook dialing and voice contact features.
- ⑪ **MUTE button** (page 13)
Used for voice muting.
- ⑫ **REDIAL/PAUSE button** (pages 13 and 47)
Used to redial the last dialed number. Also used to insert a pause into a phone number.
- ⑬ **FLASH button** (page 47)
Used as a hook button. Also used to access some features of your host exchange.
- ⑭ **STOP button** (page 16)
Used to stop fax communication.
- ⑮ **COPY button** (page 25)
Used to start copying.
- ⑯ **START/SET button**
Used to start fax communication. Also used to store parameters during programming.
- ⑰ **VOLUME buttons** (page 10)
Used to adjust the volume level of the ringer, speaker and handset.

Installing Your Unit

Installing the recording paper

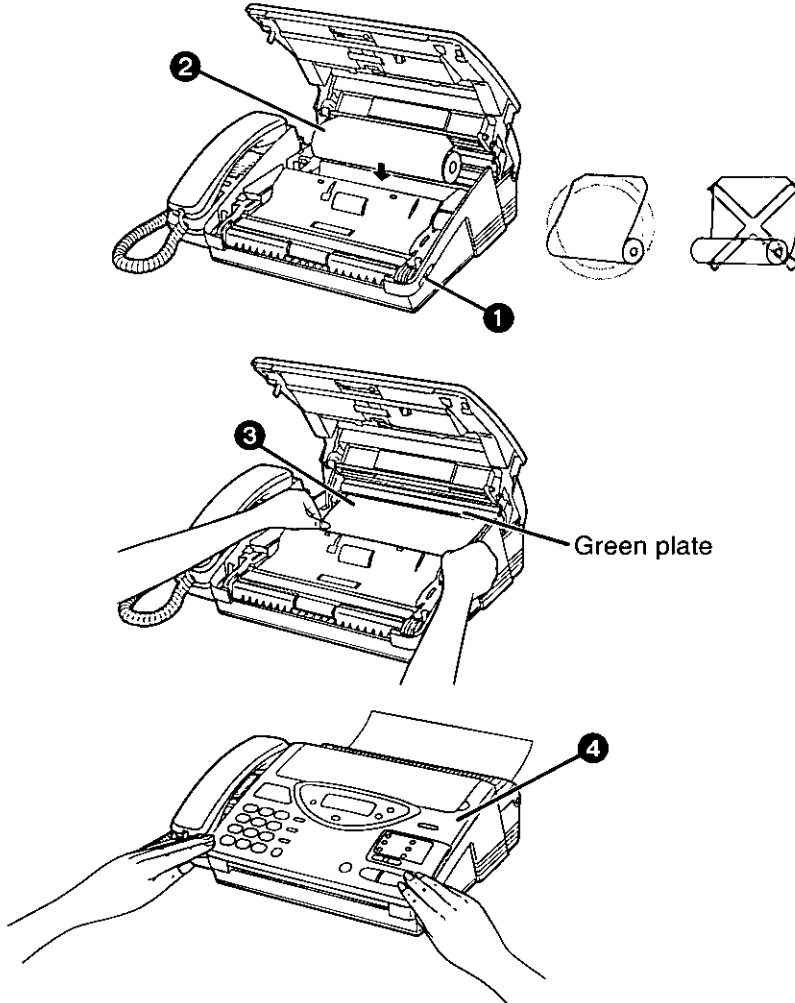

Installing the paper stacker

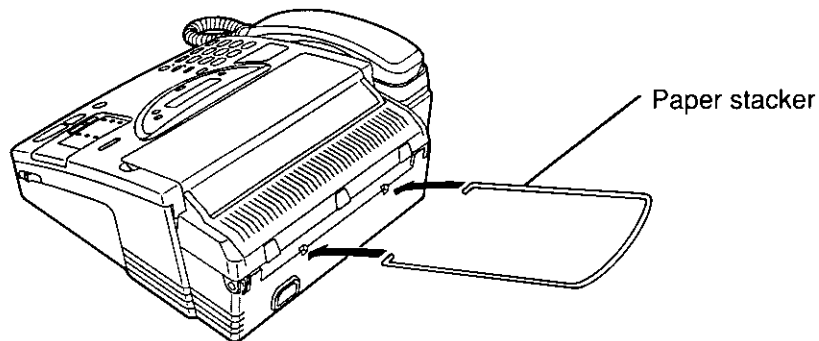

Connections and dialing mode setting

1

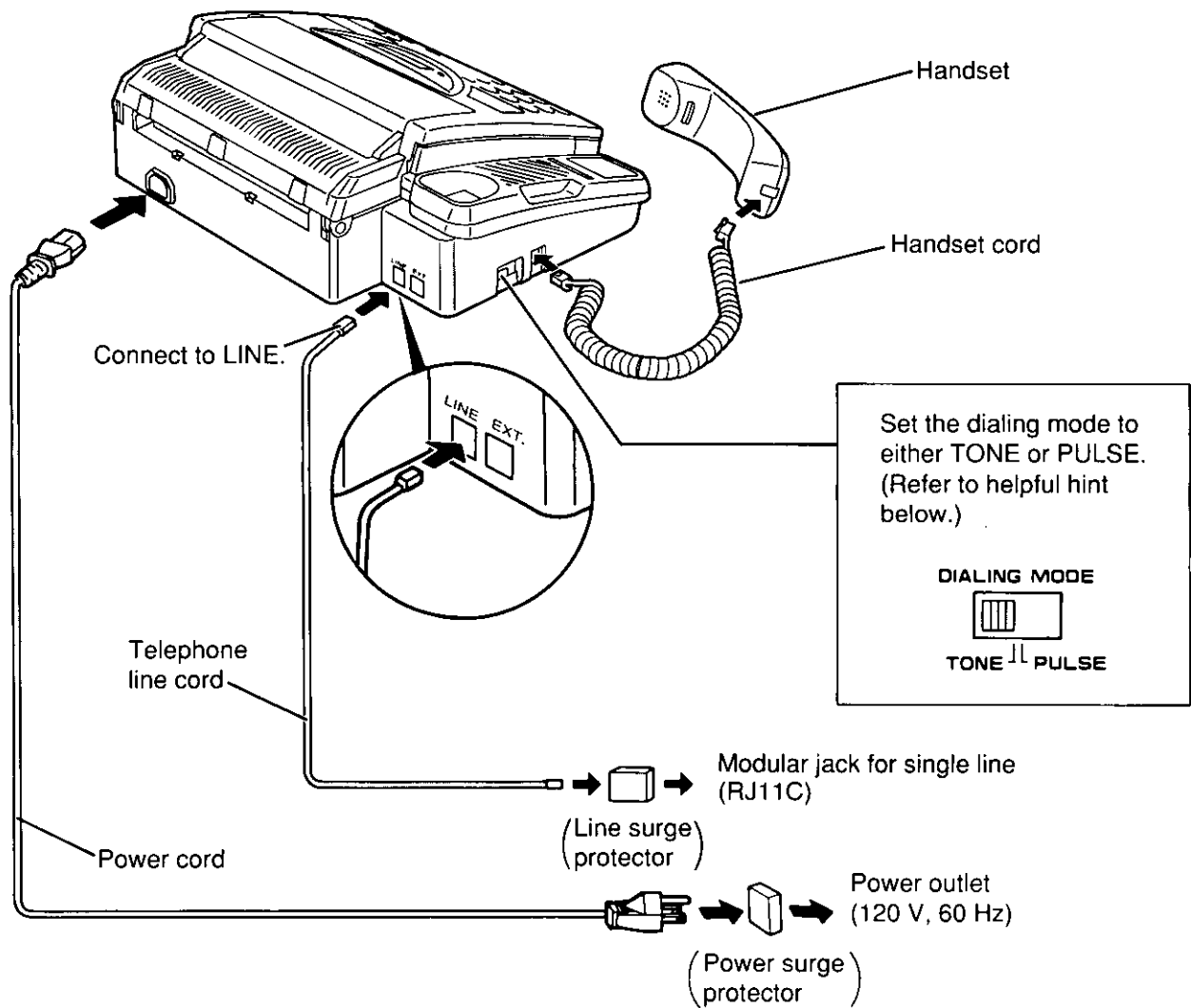

Helpful hint for setting the dialing mode:

1. Ensure that the dialing mode selector is set to TONE.
2. Lift the handset or press the SP-PHONE button, then listen for the dial tone.
3. Dial a familiar number.
4. If the call is successful, the unit is connected to a tone exchange. Leave the selector set to TONE.
5. If the call is not successful, the unit is connected to a pulse exchange. Switch the selector to PULSE.

Notes:

- We recommend the use of an exclusive power outlet to avoid interference from other equipment.
- When you operate this product, the socket outlet should be near the product and be easily accessible.
- The unit will not function during a power failure.
- You can connect an external telephone/answering machine to the unit after peeling off the tape on the external telephone jack (EXT.). When you use with an answering machine, see page 18.
- For additional equipment protection, we recommend the use of a surge protector. The following type is available; TELESPIKE BLOK MODEL TSB (TRIPPE MFG. CO.), SPIKE BLOK MODEL SK6-0 (TRIPPE MFG. CO.), SUPER MAX (PANAMAX) or MP1 (ITW LINX).

Adjusting Volumes

You can adjust the volume level of the ringer, the handset and the speaker. These volume levels should be adjusted respectively.

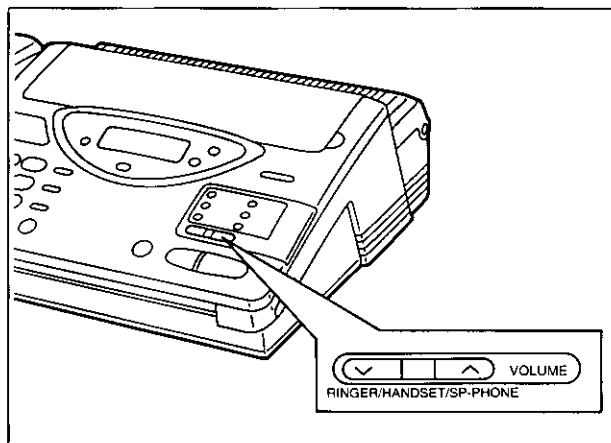

To increase the volume level, press \wedge repeatedly.

To decrease the volume level, press ∇ repeatedly.

—The number of the black squares in the display shows the volume level as below.

Ringer volume

Press the buttons (\wedge/∇) repeatedly while the unit is in idle status. 3 levels are available.

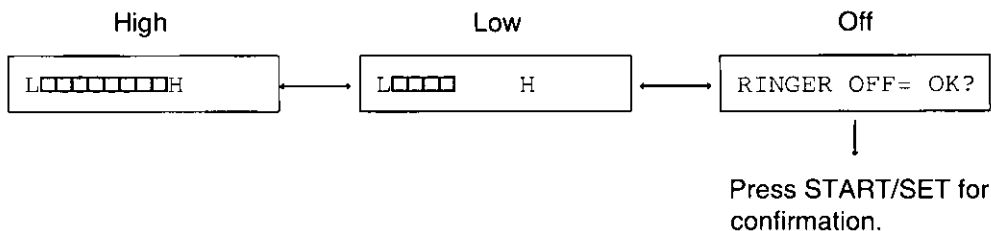

Note:

- If the ringer volume is set to off, the unit will not ring and the display will show "RINGER OFF" in idle status.

Handset volume

Press the buttons (\wedge/∇) repeatedly when the handset is in use. 3 levels are available.

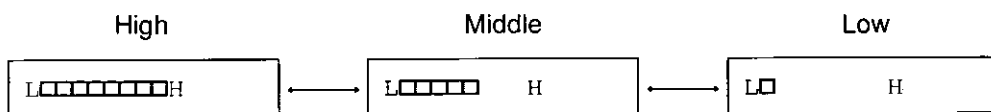

Speaker volume

Press the buttons (\wedge/∇) repeatedly when the speakerphone is in use. 8 levels are available.

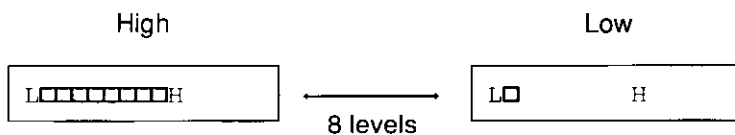

Selecting the Receive Mode

Select a desired receiving mode by pressing the **RECEIVE MODE** button repeatedly. The selected mode is displayed.

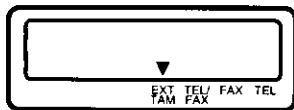
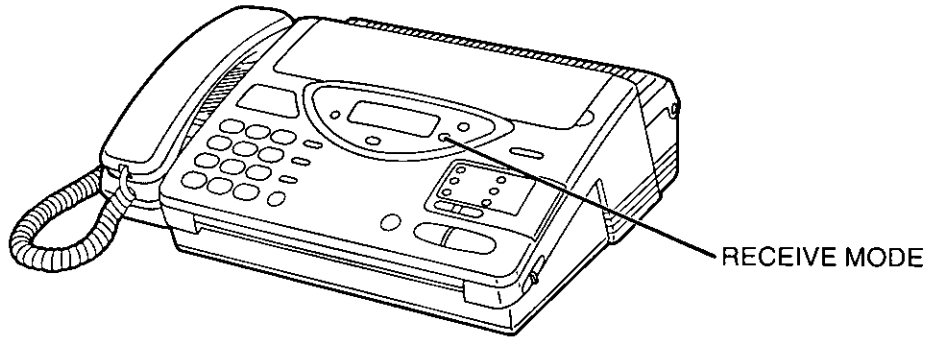

EXT. TAM mode:

When you wish to connect a telephone answering machine (TAM) to record voice messages and also wish to receive fax messages, select this mode.

For further details, see page 18.

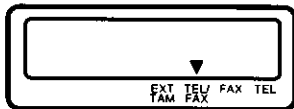

TEL/FAX mode:

When you wish to answer voice calls with ring and wish to receive fax messages without hearing ring, select this mode.

You can answer voice calls only and will not be disturbed by incoming faxes.

For further details, see page 22.

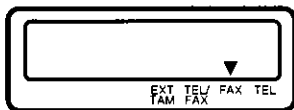

FAX mode:

When you wish to receive fax transmissions only, select this mode.

The unit will answer all calls and start to receive fax messages automatically.

For further details, see page 24.

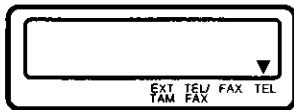

TEL mode:

When you wish to set the unit not to answer any incoming calls automatically, select this mode.

When you pick up the handset and fax reception is required, you can press the START/SET button to receive documents.

If no one answers a call by 15 rings, the receiving mode will switch to the TEL/FAX mode automatically.

Notes:

- Regardless of above setting, you can make voice and fax calls.
- If an external telephone is connected, use TEL/FAX, FAX or TEL mode.

Making and Answering Voice Calls

Making voice calls

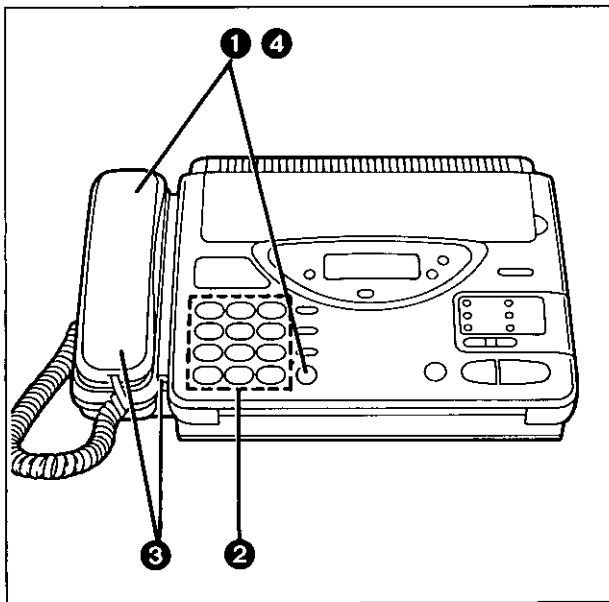

- 1 Press **SP-PHONE** or lift the handset, then listen for the dial tone.
- 2 Dial a phone number.
- 3 When the other party answers, speak through the microphone or handset.
- 4 When finished, press **SP-PHONE** again or place the handset on the cradle.

Helpful hints:

- Adjust the volume to a suitable level. See page 10.
- If you wish to switch to the handset from the speakerphone, lift the handset. To switch to the speakerphone, press the **SP-PHONE** button.
- If you misdial, press the **FLASH** button firmly, then dial the correct number.
- For helpful hints for the speakerphone operation, see page 13.

Making voice calls using automatic dialing

You can dial a phone number automatically using one-touch dialing and speed dialing. Before using automatic dialing, make sure that the desired telephone numbers have been stored in memory (see pages 32 and 33).

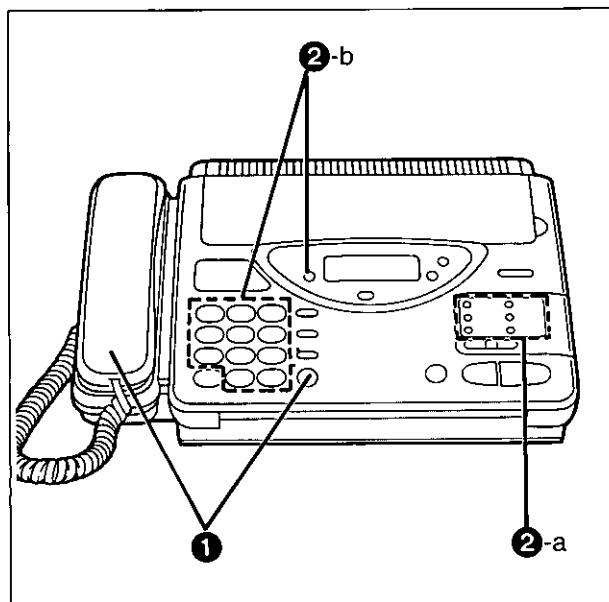

- 1 Press **SP-PHONE** or lift the handset.
- 2-a
 - **Using one-touch dialing:**
When using the upper stations 1 to 5:
Press the desired direct call station key.
 - When using the lower stations 6 to 10:
Press **LOWER**, then press the desired direct call station key.
- 2-b
 - **Using speed dialing:**
Press **DIRECTORY**, then press # and the desired 2-digit number (00–21).

Helpful hint:

- You can also use the electronic telephone directory to make a voice call (see page 34).

Redialing the last dialed number

If the line is busy or you wish to redial the last dialed number, use the REDIAL/PAUSE button.

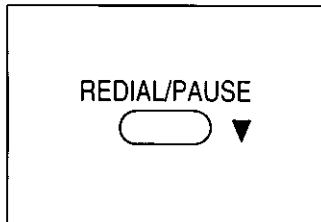

Press **SP-PHONE** or lift the handset, then press **REDIAL/PAUSE**.

Note:

- If the line is busy when using the speakerphone, the unit will automatically redial the number (see item number 8 on page 59).



Voice muting

The MUTE button will mute your voice during a telephone conversation. Using this feature, you can hear the voice of the other party, but the other party cannot hear your voice.

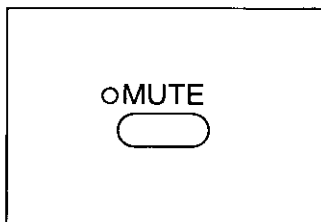

Press **MUTE** and confirm the MUTE indicator light is on.
To resume the conversation, press **MUTE** again.

Answering voice calls

When the unit rings, lift the handset or press **SP-PHONE** to answer the call.

When you have finished, replace the handset on the cradle or press **SP-PHONE**.

Note:

- For helpful hints for the speakerphone operation, see below.

Helpful hints for the speakerphone operation

- Use the speakerphone in a quiet room for best performance.
- If the other party has difficulty hearing you, decrease the volume using the VOLUME buttons (see page 10).
- If you and the other party speak at the same time, parts of your conversation will be lost. To avoid this, speak alternately.

Before Transmission

Acceptable documents

The unit can transmit documents that meet the following conditions.

- Document width should be from 128 to 216 mm (5 to 8½").
- Maximum document length should not exceed 600 mm (23⅝").
- Effective scanning width can be up to 208 mm (8⅜").
- Number of pages that can be set in the document feeder tray must not exceed 15 sheets.
- Document weight:
 - Single sheet: 45 to 90 g/m² (12 to 24 lb.)
 - Multiple sheets: 60 to 75 g/m² (16 to 20 lb.)

Minimum document size

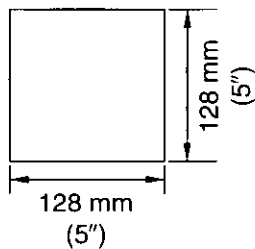

Maximum document size

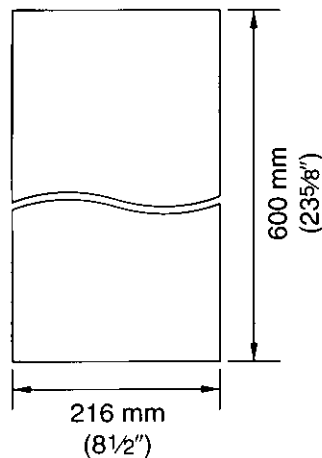

Effective scanning width

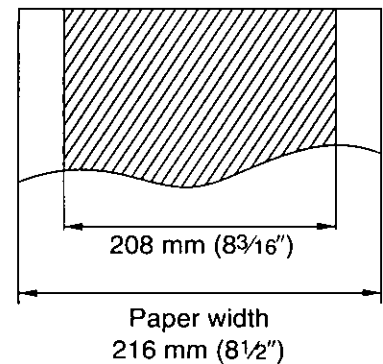

Note:

- Do not feed the following types of documents. Make a copy of these documents with a copier machine and feed the copy into the unit.
 - Paper with a chemically treated surface such as carbon paper or carbonless duplicating paper
 - Electrostatically charged paper
 - Heavily curled, creased or torn paper
 - Paper with a coated surface
 - Small-sized paper such as a slip or voucher
 - Thin paper less than 45 g/m² (12 lb.)
 - Thick paper over 90 g/m² (24 lb.)
 - Paper with faint contrast between the printing and the background
 - Paper with printing on the reverse side that can be seen through the front (e.g. newspaper)

Loading documents

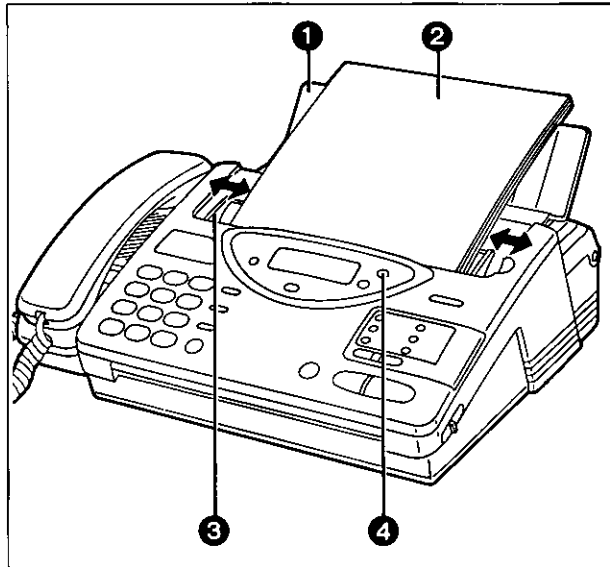

- ❶ Open the document feeder tray.
- ❷ Insert the documents **FACE DOWN** until a beep tone is heard.
—The unit can accept up to 15 sheets of paper at a time.
- ❸ Adjust the document guides to the width of the documents.
- ❹ Adjust the resolution by pressing **RESOLUTION** if needed (see below).

Notes:

- Remove clips, staples or other similar objects from a document before feeding it into the unit. Also check that all ink, paste or correction fluid on the document has completely dried.
- If the top edge of the document is curled, make it flat and insert the document.

Setting resolution

Depending on the quality of the originals, you can select the desired resolution by pressing the **RESOLUTION** button repeatedly. Use the button when the document has been fed into the unit.

STANDARD

Suitable for printed or typewritten originals with normal-sized characters.

FINE

Suitable for originals with small printing.

SUPER FINE

Suitable for originals with minute printing.

HALF TONE

Useful for originals containing photographs, shaded drawings, etc.

Notes:

- Using these features except the standard resolution will increase the transmission time.
- The super fine resolution only works between other compatible machines.
- If the setting is changed during feeding, it will be effective from the next sheet.
- To enhance the resolution settings, see page 45.

Sending 16 or more sheets

If you wish to send 16 or more sheets at a time, insert the first 15 sheets of the document. Add the extra sheets, up to 15 sheets at a time, before the last sheet is fed into the unit.

Transmitting Documents

Transmitting documents manually

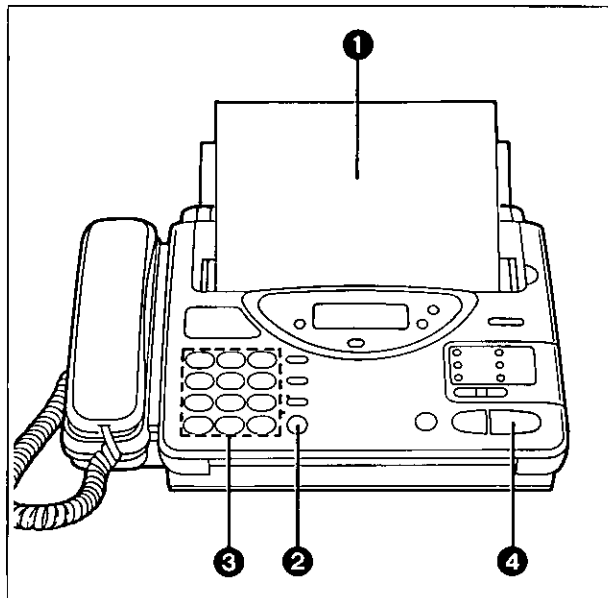

- 1 Insert the documents **FACE DOWN** until a beep tone is heard.
- 2 Press **SP-PHONE** or lift the handset, then listen for the dial tone.
- 3 Dial a phone number.
- 4 When a fax tone is heard, press **START/SET**.
- 5 Place the handset on the cradle if using it.
—The unit will start transmission.

Notes:

- If the other party answers your call, ask them to press their start or transmit button to start the fax reception, then press your **START/SET** button.
- If there is a misdial in step 3, press the **FLASH** button firmly, then dial the correct number after the dial tone is heard.
- To interrupt the transmission, press the **STOP** button.

Transmitting documents with fewer procedures

You can transmit documents without using the handset or the SP-PHONE button.

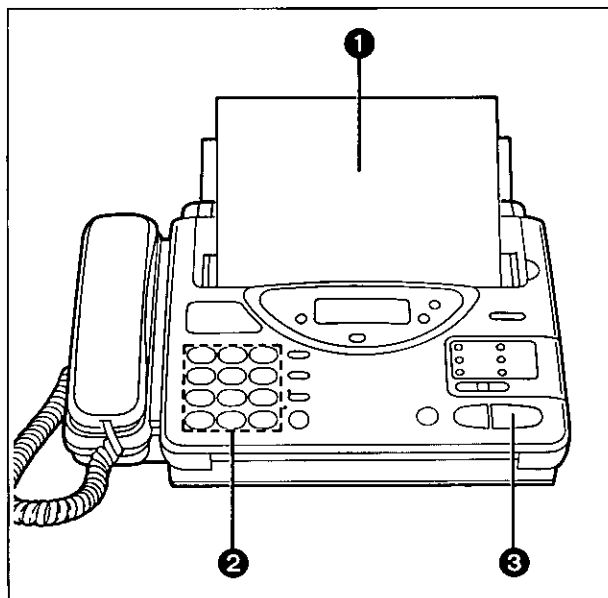

- 1 Insert the documents **FACE DOWN** until a beep tone is heard.
- 2 Enter the phone number.
—If incorrect, press the **STOP** button, then enter the correct number.
- 3 Press **START/SET**.
—The unit will start to dial and transmit the documents.

Note:

- If there is no answer or the line is busy, the unit will automatically redial the number (see item number 7 on page 59).

Transmitting documents using automatic dialing

You can transmit documents automatically using one-touch dialing and speed dialing. Before using automatic dialing, make sure that the desired telephone numbers have been stored in memory (see pages 32 to 33).

Using one-touch dialing:

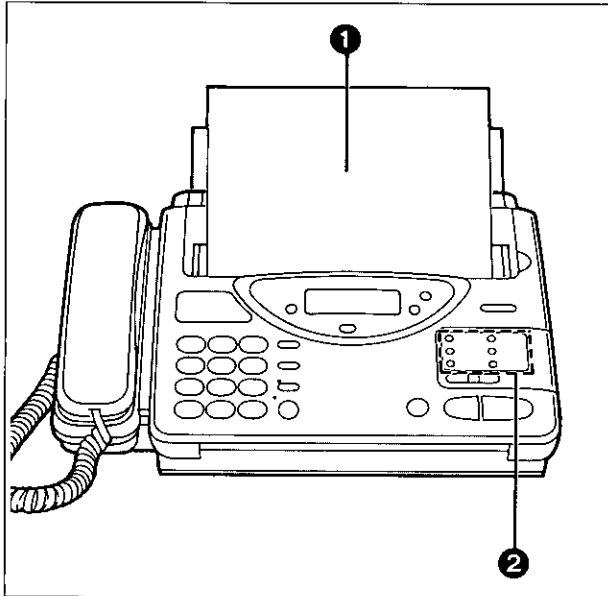

❶ Insert the documents FACE DOWN until a beep tone is heard.

❷ **When using the upper stations 1 to 5:**
Press the desired direct call station key.

When using the lower stations 6 to 10:
Press **LOWER**, then press the desired direct call station key.

—The unit will dial and transmit the documents automatically.

Note:

● If there is no answer or the line is busy, the unit will automatically redial the number (see item number 7 on page 59).

Using speed dialing:

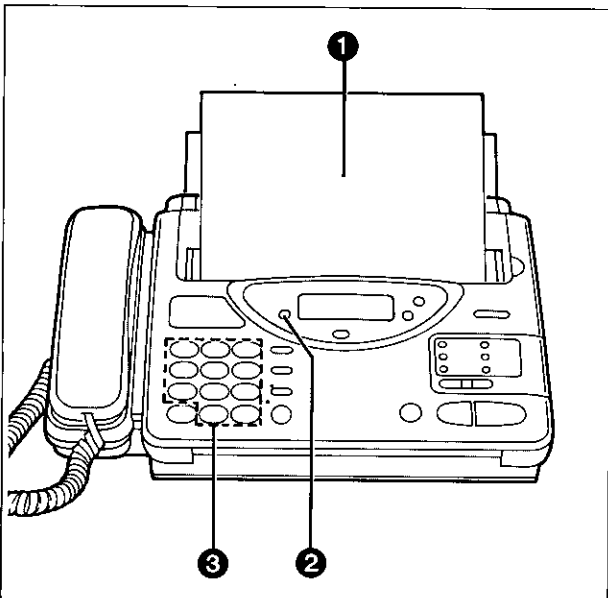

❶ Insert the documents FACE DOWN until a beep tone is heard.

❷ Press **DIRECTORY**.

❸ Press #, then press the desired 2-digit number (00–21).

—The unit will dial and transmit the documents automatically.

Note:

● If there is no answer or the line is busy, the unit will automatically redial the number (see item number 7 on page 59).

Receiving Documents and/or Voice Calls

Manual reception

When in the *TEL* mode or during a telephone conversation, you can receive documents as follows.

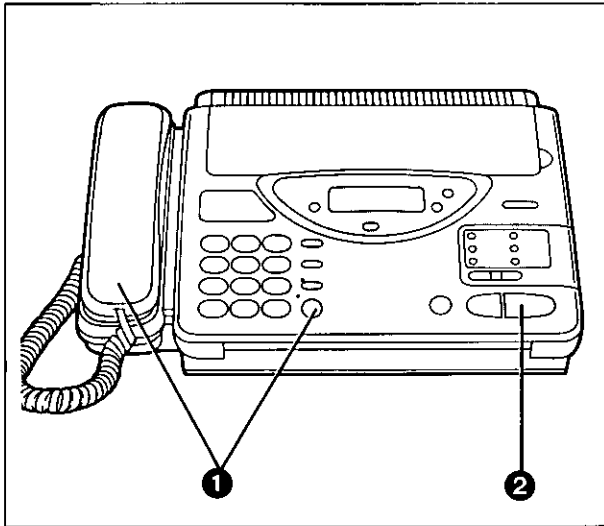

- 1 When the unit rings, press **SP-PHONE** or lift the handset to answer the call.
- 2 When document reception is required, or a slow beep or nothing is heard, press **START/SET**.
- 3 Place the handset on the cradle if using it.
—The unit will start reception.

Note:

- To interrupt reception, press the **STOP** button.
The unit will stop receiving.

Automatic reception

Set the receive mode to *EXT.*, *TAM*, *TEL/FAX* or *FAX* by pressing **RECEIVE MODE**.

When a fax call comes in, the unit will automatically activate the fax function to receive documents.

Receiving in the *EXT.* *TAM* mode

This mode is used only when an external telephone answering machine (TAM) has been connected to the facsimile unit. Incoming voice messages will be recorded on the telephone answering machine and fax calls will be received by the facsimile unit automatically.

Connection

Connect the telephone answering machine to the jack marked "EXT.".

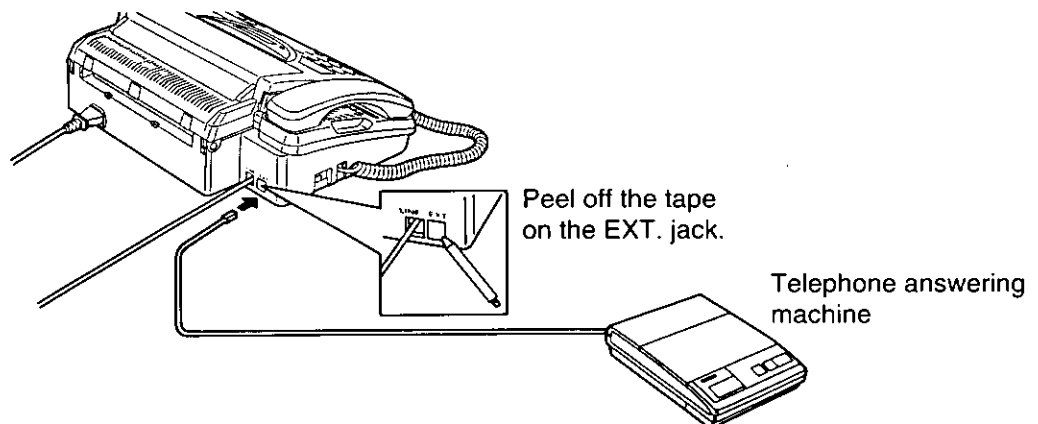

How to receive incoming calls in the EXT. TAM mode

When a call comes in, the facsimile unit and the external telephone answering machine will work as follows.

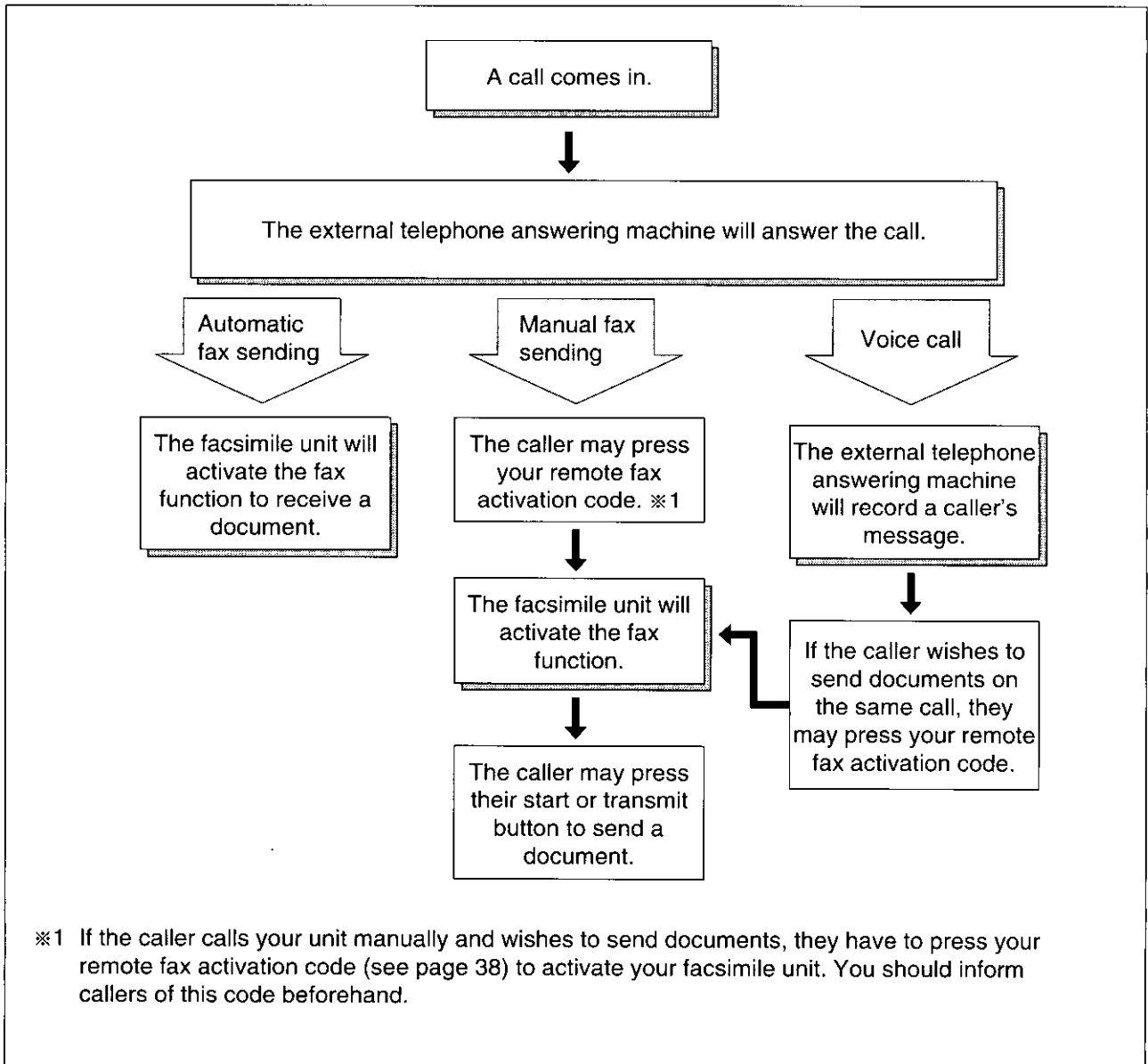

Helpful hint:

- When you use the unit with a telephone answering machine, transmit the FAX CORRESPONDENCE leaflet on page 63 to several your associates. In this way, you can confirm that your facsimile unit and telephone answering machine will function correctly and inform them of the procedure for transmitting documents and/or recording voice-message.

Setting up the answering machine





1. Set the number of rings on the telephone answering machine to 1–4.
2. Record your greeting message referring to the example below.
 “This is (your name, business and/or telephone number). We are unable to answer right now. To leave a message, speak after the long beep. To send a fax, press your asterisk button twice (remote fax activation code) and start transmission. Thank you.”
 —Do not pause more than 4 seconds in the message.
 —Record your message for 8–16 seconds. We recommend you keep it around 10 seconds in length.
3. If your external telephone answering machine is equipped with a remote operation feature, you must set the same remote access code (remote TAM activation ID) as stored on the telephone answering machine in the unit’s memory. See below.

Setting the remote TAM activation ID

Your code can be from 1 to 5 digits long. The numbers 0 through 9 and characters # and * may be used.

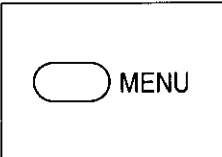
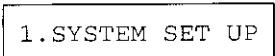
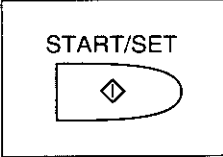
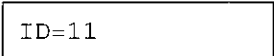
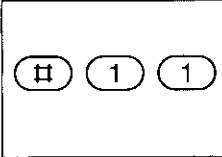
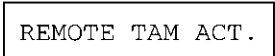
Important:

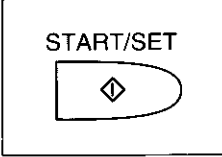
- Note that the code should be different from the remote fax activation code (see page 38) and the junk mail prohibitor ID (see page 39).

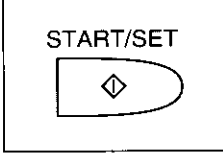
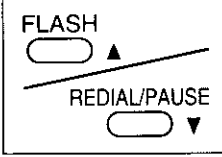
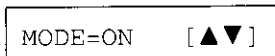
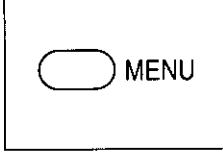
<p>1</p> 	<p>Press MENU.</p>		<p>5</p> 	<p>Press START/SET.</p>	
<p>2</p> 	<p>Press #, then press 11.</p>		<p>6</p> 	<p>Enter the new ID number.</p>	
<p>3</p> 	<p>Press START/SET.</p>		<p>7</p> 	<p>Press START/SET to store the number.</p>	
<p>4</p> 	<p>Press ▲ or ▼ repeatedly to select “ON”.</p>		<p>8</p> 	<p>Press MENU to end the program.</p>	

Setting the silent detection

This feature allows the facsimile unit to activate the fax function automatically when a silent pause longer than 4 seconds is detected in the EXT. TAM mode.

Helpful hints:

- If you wish to receive documents from stations that do not send calling tone (CNG) after dialing, set this feature to "ON".
- If you use a single cassette tape to give a greeting message and to record incoming messages, set this feature to "OFF".

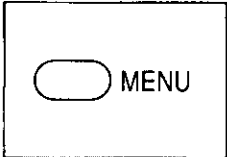
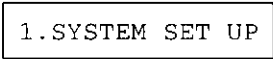
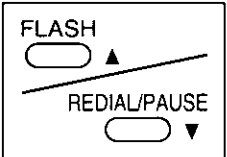
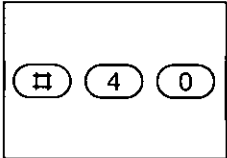
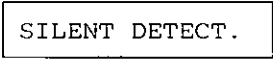
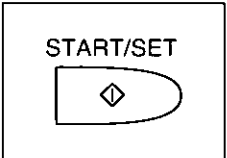
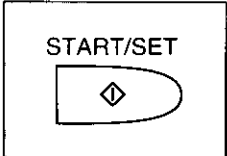
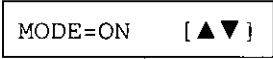
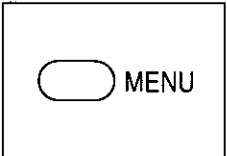
<p>1</p> 	<p>Press MENU.</p> 	<p>4</p> 	<p>Press ▲ or ▼ to select the desired mode.</p>
<p>2</p> 	<p>Press #40.</p> 	<p>5</p> 	<p>Press START/SET to store the setting.</p>
<p>3</p> 	<p>Press START/SET.</p> 	<p>6</p> 	<p>Press MENU to end the program.</p>

Notice when using with an answering machine

- Every time the facsimile unit receives a document, a mute or a fax tone may be recorded on the tape.
- Advise callers that they should not pause for over 4 seconds while recording their messages. If they do, the facsimile unit may activate the fax function.
- When your answering machine runs out of a recording tape, your facsimile unit may not be able to receive a document. Rewind the tape and prepare for recording.
- When you set the answering machine to give only a greeting message, a fax reception may not be available. We recommend to set your answering machine to record messages.
- If you answer a call with the answering machine and pause for over 4 seconds, the facsimile unit may activate the fax function and you may not be able to talk with the other party. To resume the conversation, press the STOP button on the facsimile unit.
- When the answering machine does not answer a call after ringing 5 times, the facsimile unit will activate the fax function.
- Set the receive mode of the facsimile unit to TEL in the following conditions:
 - when you wish to set the number of rings on the answering machine to more than 5.
 - when you wish to use auto transfer functions (transfer, pager call, etc.) on the answering machine.
 Note that automatic fax sending (see page 19) can not be received automatically in the TEL mode.

Receiving in the TEL/FAX mode

When a call comes in, the unit will work as follows.

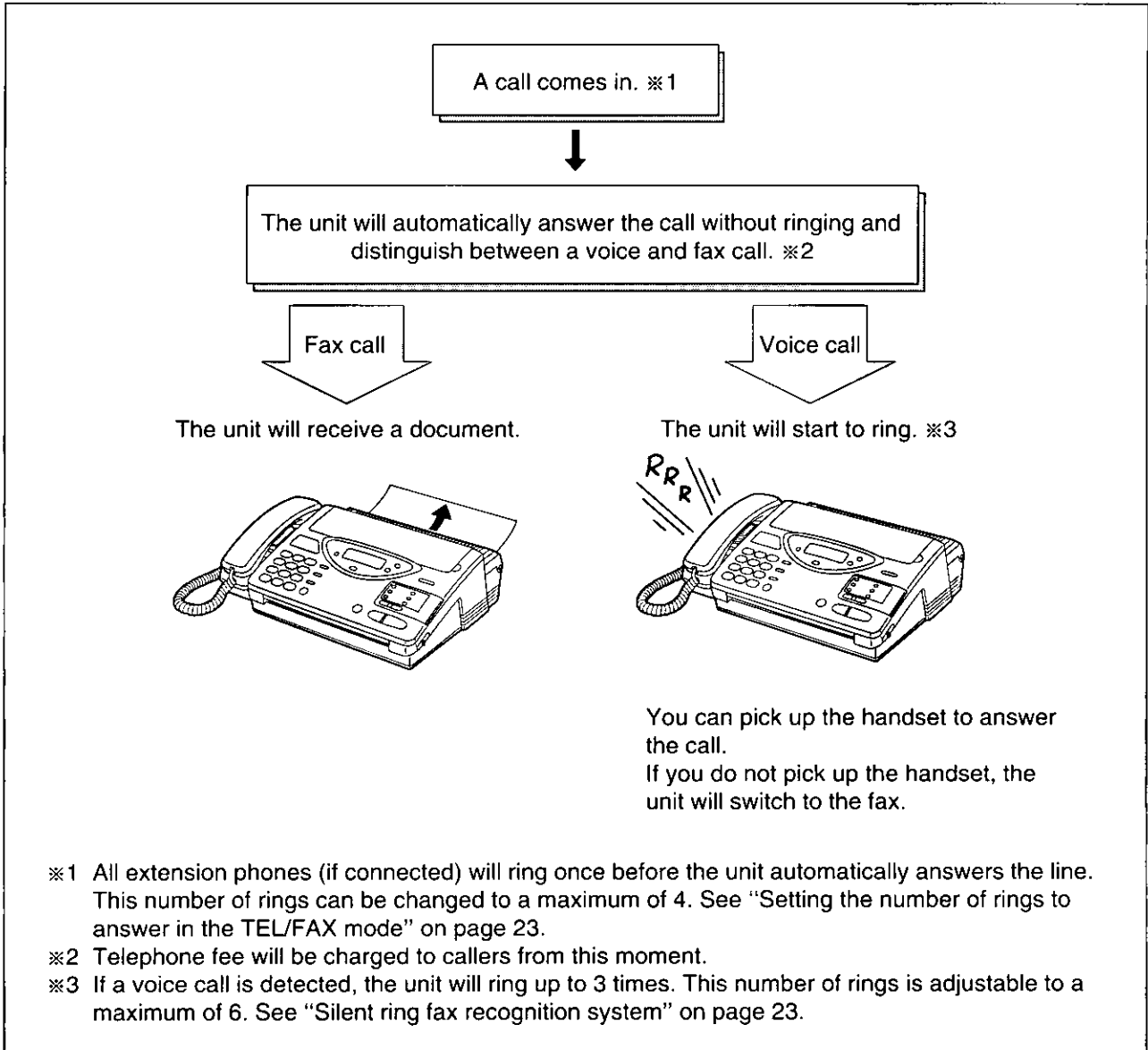

Notes:

- The unit can distinguish between a voice and fax call by detecting the calling tone (CNG), sent by the transmitting fax machines.
Some fax messages that are transmitted manually may not send with a calling tone. These calls must be manually received after the unit rings and the call is answered.
- If a voice call is received, the unit will start to ring. While ringing, the unit will emit a different ring back tone to the calling party.
- If you hear the facsimile unit ringing, you can pick up the handset on the facsimile unit or another extension (if connected on the same line) to answer the call.

Setting the number of rings to answer in the TEL/FAX mode

This feature determines the number of rings after which the unit answers a call in the TEL/FAX mode. You can change the number of rings from 1 to 4 rings.

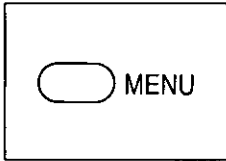
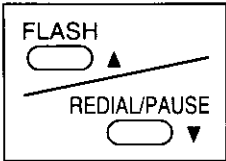
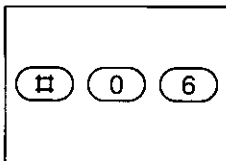
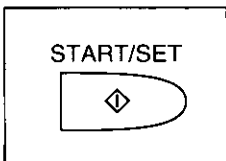
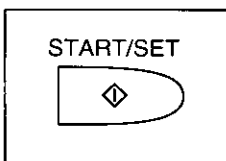
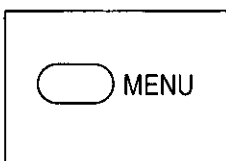
- | | | | |
|---|--|--|---|
| <p>1</p>  | <p>Press MENU.</p> <div style="border: 1px solid black; padding: 2px; width: fit-content; margin: 5px auto;">1. SYSTEM SET UP</div> | <p>4</p>  | <p>Press ▲ or ▼ to select the desired number of rings (1 to 4).</p> |
| <p>2</p>  | <p>Press #06.</p> <div style="border: 1px solid black; padding: 2px; width: fit-content; margin: 5px auto;">TEL/FAX RING</div> | <p>5</p>  | <p>Press START/SET to store the setting.</p> |
| <p>3</p>  | <p>Press START/SET.</p> <div style="border: 1px solid black; padding: 2px; width: fit-content; margin: 5px auto;">RING=1 [▲▼]</div> | <p>6</p>  | <p>Press MENU to end the program.</p> |

Note:

- If an external telephone with a caller ID or call display feature is connected, set the number of rings to more than 2.

Silent ring fax recognition system

In the TEL/FAX mode, when a fax call is received, the unit will automatically activate the fax function without ringing (we call this "silent ring fax recognition system"). If the unit detects a voice call, it will ring 3 times. This number of rings can be changed to a maximum of 6 by following steps below.

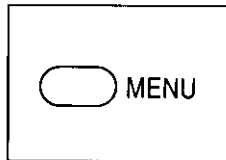
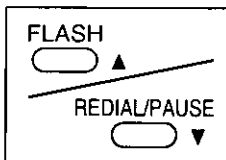
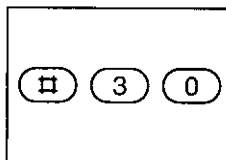
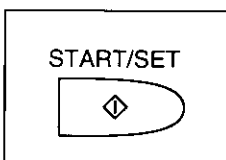
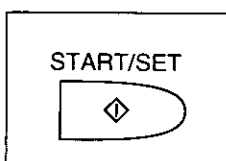
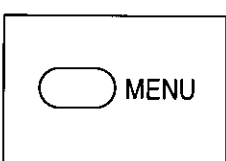
- | | | | |
|---|--|--|--|
| <p>1</p>  | <p>Press MENU.</p> <div style="border: 1px solid black; padding: 2px; width: fit-content; margin: 5px auto;">1. SYSTEM SET UP</div> | <p>4</p>  | <p>Press ▲ or ▼ to select the desired number (choose from 3 to 6).</p> |
| <p>2</p>  | <p>Press #30.</p> <div style="border: 1px solid black; padding: 2px; width: fit-content; margin: 5px auto;">SILENT FAX RING</div> | <p>5</p>  | <p>Press START/SET to store the setting.</p> |
| <p>3</p>  | <p>Press START/SET.</p> <div style="border: 1px solid black; padding: 2px; width: fit-content; margin: 5px auto;">RING=3 [▲▼]</div> | <p>6</p>  | <p>Press MENU to end the program.</p> |

Receiving in the FAX mode

When a call comes in, the unit will automatically answer the line after 1 to 4 rings (user programming) and activate the fax function.

Setting the number of rings in the FAX mode

This feature determines the number of rings after which the unit answers a call in the FAX mode. You can change the number of rings from 1 to 4 rings.

Helpful hints:

- If you wish to have the opportunity to answer a call before the unit does, increase the number of rings.
- If you find there is difficulty in fax receiving from machines that have an automatic transmission feature, decrease the number of rings.
- If an external telephone with a caller ID or call display feature is connected, set the number of rings to more than 2.

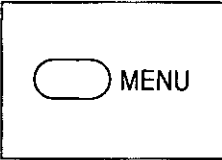
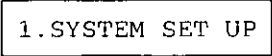
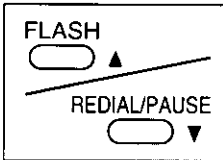
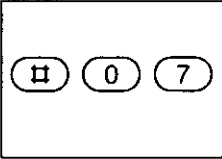
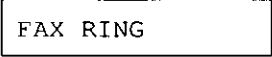
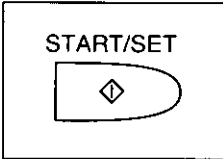
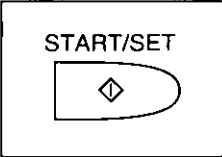
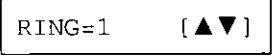
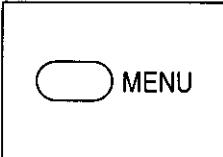
<p>1</p> 	<p>Press MENU.</p> 	<p>4</p> 	<p>Press ▲ or ▼ to select the desired number of rings (1 to 4).</p>
<p>2</p> 	<p>Press #07.</p> 	<p>5</p> 	<p>Press START/SET to store the setting.</p>
<p>3</p> 	<p>Press START/SET.</p> 	<p>6</p> 	<p>Press MENU to end the program.</p>

Making a Copy

Any transmissible document can be copied (see page 14). To make a copy, follow the steps below.

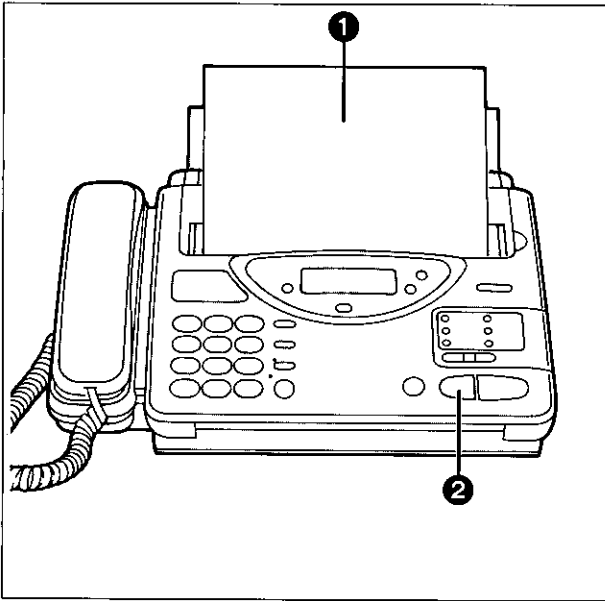

- ❶ Insert the documents FACE DOWN.
- ❷ Press **COPY**.
—The unit will start copying.

Notes:

- When copying, the unit will automatically select the FINE resolution. Depending on the originals, select the desired resolution (see page 15).
- You can make or receive voice calls while making a copy.
- To interrupt a copy, press the STOP button. The unit will stop copy operation and eject the documents.

User Programmable Features

The unit has the following programming features.

Basic features are the settings that need to be programmed upon completing the installation. Most probable choices have been pre-selected, but some features, such as codes #01, #02 and #03, must be programmed by user.

Advanced features should be programmed as the need arises.

Programming feature table

Basic features

Code	Feature	Description	Selection	Page
#01	SET DATE & TIME	Setting the current date and time		30
#02	YOUR LOGO	Setting your company name or personal name	up to 30 digits	30
#03	YOUR TELEPHONE NUMBER	Setting your facsimile telephone number	up to 20 digits	31
#04	PRINT TRANSMISSION REPORT	Setting individual transmission report printing	<u>ERROR/ON/OFF</u>	31
#06	TEL/FAX DELAYED RING	Setting the number of rings on the extension phone (if connected) before the facsimile unit answers a call in the TEL/FAX mode	<u>1</u> to 4 rings	23
#07	FAX RING COUNT	Setting the number of rings to answer in the FAX mode	<u>1</u> to 4 rings	24
#11	REMOTE TAM ACTIVATION	Setting the same remote control code as stored on the telephone answering machine	<u>ON/OFF</u> ID=up to 5 digits <u>(11)</u>	20

Note: In the "Selection" column, the underlined print indicates the pre-selected settings.

Advanced features

Code	Feature	Description	Selection	Page
#21	LOGO POSITION	Setting the logo print position on the transmitted document	<u>OUT</u> /IN/OFF	41
#22	JOURNAL AUTO PRINT	Printing journal report automatically	<u>ON</u> /OFF	51
#23	OVERSEAS MODE	Setting the overseas transmission mode	ON/ <u>OFF</u>	42
#24	JUNK MAIL PROHIBITOR	Turning on the junk mail prohibitor feature. Also setting the prohibitor ID.	ON/ <u>OFF</u> Prohibitor ID= 2 digits (<u>22</u>)	39
#25	DELAYED TRANSMISSION	Setting the delayed transmission	ON/ <u>OFF</u>	36
#30	SILENT FAX RECOGNITION RING	Setting the number of rings when receiving a voice call in the TEL/FAX mode	<u>3</u> to 6 rings	23
#33	PAPER SAVE FUNCTION	Setting the paper save reception/copy	ON/ <u>OFF</u>	43
#34	EXTENSION COPY	Copying a document twice in length	/	44
#40	SILENT DETECTION	Selecting whether or not the unit will activate fax function when a silent pause longer than 4 seconds occurs in the EXT. TAM mode after the call is answered.	<u>ON</u> /OFF	21
#41	REMOTE FAX ACTIVATION CODE	Setting the remote fax activation code for remote receiving using an extension phone	up to 4 digits (<u>**</u>)	38
#46	ORIGINAL SETTING	Setting the contrast mode	<u>NORMAL</u> / LIGHT/ DARKER	45
#80	SET DEFAULT	Resetting the parameters of the advanced features	YES/ <u>NO</u>	45

Note: In the "Selection" column, the underlined print indicates the pre-selected settings.

How to enter letters and symbols

The dial keypad and the direct call station 1 are used as alphabet and symbol character input keys when you enter your logo and station names for automatic dialers.

To enter characters

Pressing each key will alternately select a character as shown below. When the desired character is displayed, press # to move the cursor to the right and enter the next character.

Keys	Number of pressing times												
	1	2	3	4	5	6	7	8	9	10	11	12	13
①	1	[]	{	}	+	-	/	=	,	.	_	'
②	A	B	C	a	b	c	2						
③	D	E	F	d	e	f	3						
④	G	H	I	g	h	i	4						
⑤	J	K	L	j	k	l	5						
⑥	M	N	O	m	n	o	6						
⑦	P	Q	R	S	p	q	r	s	7				
⑧	T	U	V	t	u	v	8						
⑨	W	X	Y	Z	w	x	y	z	9				
⑩	0	()	<	>	!	"	#	\$	%	&	¥	
○	:	;	?		*	@	^	'	→				
✳	◀ key (Used to move the cursor to the left)												
⏪	▶ key (Used to move the cursor to the right)												

For example, when entering "Mike" as your logo:

- ① Press 6 once, then press #.

LOGO=M

- ② Press 4 six times, then press #.

LOGO=Mi

- ③ Press 5 five times, then press #.

LOGO=Mik

- ④ Press 3 five times.

LOGO=Mike

Note:

- If you make a mistake while programming, use # or ✳ to move the cursor to the incorrect character, then make the correction.

Special uses of the direct call station keys

Direct call stations 2, 4 and 5 are used as command keys.

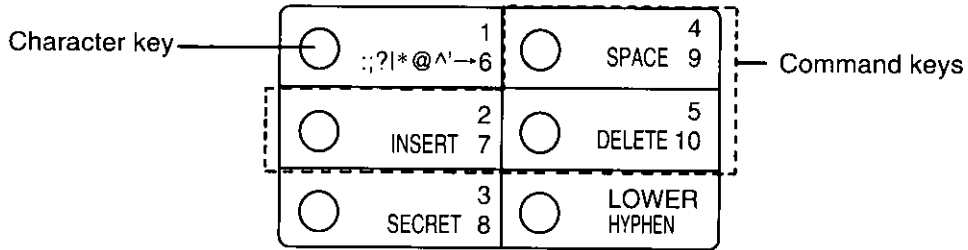

The layout of the direct call station keys is printed on the reverse side of the directory card.

1. Remove the directory card cover with a pencil or similar object as shown.
2. Turn over the directory card. You will find how each command is assigned to the direct call station keys.

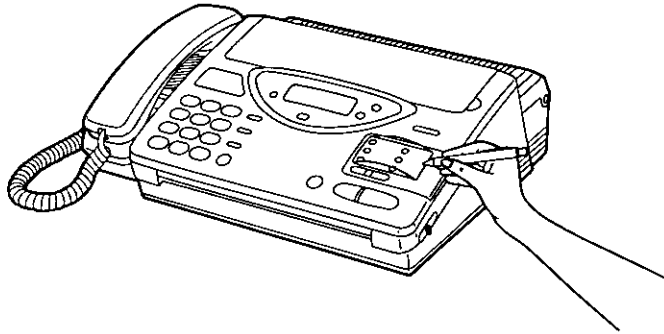

■ Direct call station 2 (INSERT):

This key is used to insert one character (or one space) in the programmed logo.

Example: Compny→Company

1. Press # or * repeatedly until the cursor is positioned on "n".

LOGO=Compny

2. Press **INSERT**.

LOGO=Comp ny

3. Press **2** repeatedly until "a" is shown.

LOGO=Company

■ Direct call station 4 (SPACE):

This key is used to replace one character to the space.

Example: Com pany→Company

1. Press # or * repeatedly until the cursor is positioned on "n".





LOGO=Com pany

2. Press **DELETE**.

LOGO=Company

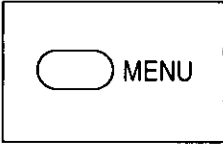
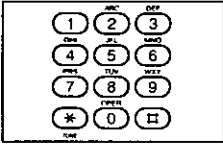
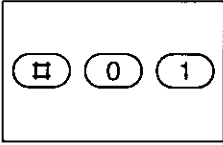
Setting the date and time

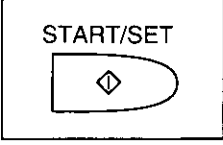
The internal clock of the unit will print the date and time, on the top line of all fax messages you transmit, and on the fax communication reports such as the journal report and the transmission report.

<p>1</p> 	<p>Press MENU.</p> <div style="border: 1px solid black; padding: 2px; width: fit-content; margin: 5px auto;">1.SYSTEM SET UP</div>	<p>4</p> 	<p>Enter the current month/day/year/hour/minute by selecting each 2 digits. Then press * for AM or press # for PM.</p>
<p>2</p> 	<p>Press #01.</p> <div style="border: 1px solid black; padding: 2px; width: fit-content; margin: 5px auto;">SET DATE & TIME</div>	<p>Example: <i>Aug. 10 1994, 3:00 PM</i> Press 08 10 94 03 00, then press # to select PM.</p>	
<p>3</p> 	<p>Press START/SET.</p> <div style="border: 1px solid black; padding: 2px; width: fit-content; margin: 5px auto;">01/01/94 12:00A</div>	<p>5</p> 	<p>Press START/SET to store the setting.</p>
		<p>6</p> 	<p>Press MENU to end the program.</p>

Notes:

- When you make a mistake while programming, press the STOP button, then make the correction.
- The accuracy of the clock will be approximately ± 45 seconds a month at room temperature.

Setting your logo

The logo is used to identify fax messages that are being transmitted by your unit. It may consist of alpha-numeric letters and symbols. Usually the logo is a company, division or personal name in an abbreviated form.

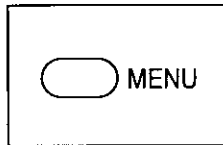
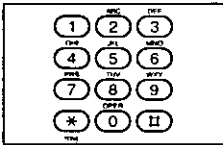
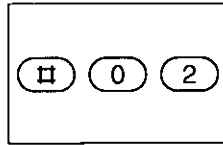
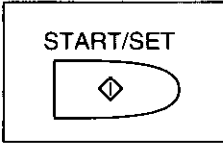
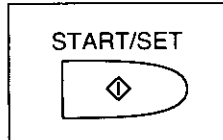
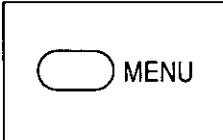
<p>1</p> 	<p>Press MENU.</p> <div style="border: 1px solid black; padding: 2px; width: fit-content; margin: 5px auto;">1.SYSTEM SET UP</div>	<p>4</p> 	<p>Enter your logo up to 30 characters by following the instructions on page 28.</p>
<p>2</p> 	<p>Press #02.</p> <div style="border: 1px solid black; padding: 2px; width: fit-content; margin: 5px auto;">YOUR LOGO</div>	<p>5</p> 	
<p>3</p> 	<p>Press START/SET.</p> <div style="border: 1px solid black; padding: 2px; width: fit-content; margin: 5px auto;">LOGO=</div>	<p>6</p> 	<p>Press MENU to end the program.</p>

Note:

- When the first character is entered, the preset logo will be cleared.



Setting your facsimile telephone number

Your programmed phone number will be printed on the top of each page transmitted from your unit.

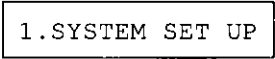
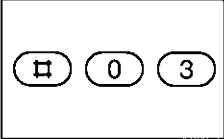
- 1**  Press **MENU**.

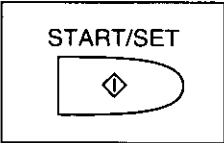
- 2**  Press **#03**.

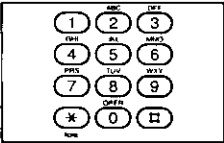
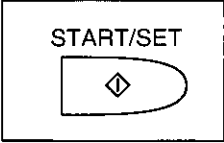
- 3**  Press **START/SET**.

- 4**  Enter your facsimile telephone number up to 20 digits.
—The # button provides a space and the * button provides “+”.
- 5**  Press **START/SET** to store the setting.
- 6**  Press **MENU** to end the program.

Setting the transmission report printing

Each time a document is transmitted, this feature will give you a printed record of the transmission.

The following choices are available:

ERROR: The report will print only when the transmission fails.

ON: The report will print, indicating whether the transmission is successful or not.

OFF: The report will not print.

Sample of transmission report:

XMT REPORT						
						Jan. 01 1994 12:09AM
NO.	OTHER FACSIMILE	START TIME	USAGE TIME	MODE	PAGES	RESULT
01	COMPANY ABC	Jan. 01 12:08AM	01'05	TX	01	OK

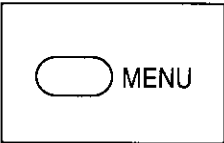
- 1**  Press **MENU**.

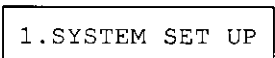
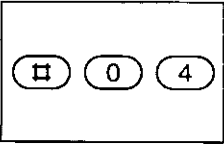
- 2**  Press **#04**.

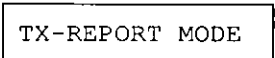
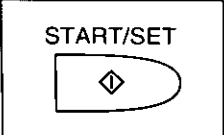
- 3**  Press **START/SET**.

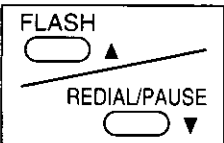
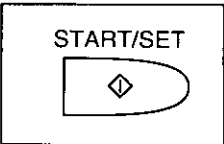
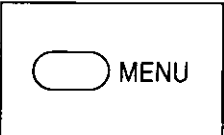
- 4**  Press **▲** or **▼** to select the desired mode.
- 5**  Press **START/SET** to store the setting.
- 6**  Press **MENU** to end the program.

Storing Phone Numbers for Automatic Dialing

The unit's memory allows you to use both one-touch dialing (up to 10 phone numbers) and speed dialing (up to 22 phone numbers) for rapid access to your most frequently dialed numbers.

One-touch dialing: The unit is equipped with 5 direct call station keys, each of which is divided into an upper station and a lower station.

Speed dialing: The unit is equipped with additional 22 dialing stations. These stations are assigned to 2-digit numbers (00–21).

Storing phone numbers for one-touch dialing

Each station can store a phone number up to 30 digits in length and the associated station name up to 10 alpha-numeric characters.

1  Press **MENU** repeatedly until the following is displayed.

2. STORE TEL NO.

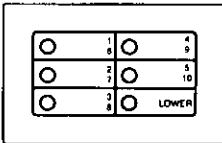
2  **For upper stations 1 to 5:** Press one of the direct call station keys.
Example: Station 4

<S04>=

or

For lower stations 6 to 10: Press **LOWER**, then press one of the direct call station keys.
Example: Station 8

<LWR>=

<S08>=

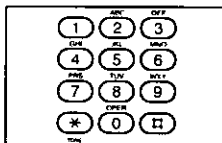
3  Enter a phone number.

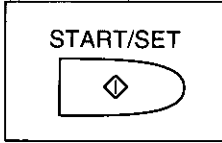
4  Press **START/SET** to store the number.

NAME=

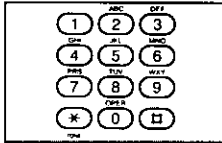
5  Enter the station name by following the instructions on page 28.

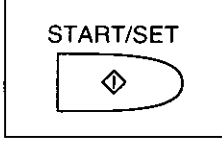
6  Press **START/SET** to store the station name.
—To program other stations, repeat from step 2.

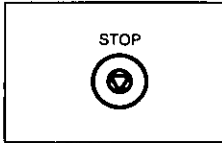
7  Press **STOP** to end the program.

Notes:

- To enter a hyphen in a phone number, press the LOWER key.
- If you make a mistake while programming, press the STOP button, then make the correction.
- To erase a programmed phone number in step 3, press the STOP button when the cursor is positioned on the beginning of the number.
- Confirm that phone numbers and their station names have been correctly stored by printing the telephone number list. See page 48.

Storing phone numbers for speed dialing

Each dialing station can store a phone number up to 30 digits in length and the associated station name up to 10 alpha-numeric characters.

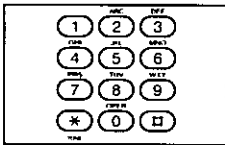
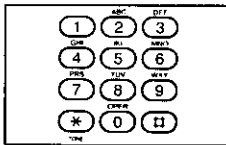
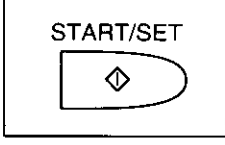
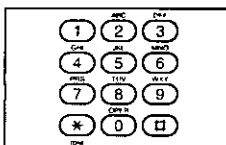
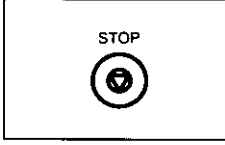
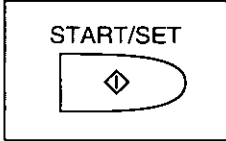
<p>1</p> 	<p>Press MENU repeatedly until the following is displayed.</p> <div style="border: 1px solid black; padding: 5px; width: fit-content; margin: 10px auto;">2.STORE TEL NO.</div>	<p>5</p> 	<p>Enter the station name by following the instructions on page 28.</p>
<p>2</p> 	<p>Press #, then press a 2-digit number (00–21). Example: Station #00</p> <div style="border: 1px solid black; padding: 5px; width: fit-content; margin: 10px auto;"><A00>=</div>	<p>6</p> 	<p>Press START/SET to store the station name. —To program other stations repeat from step 2.</p>
<p>3</p> 	<p>Enter a phone number.</p>	<p>7</p> 	<p>Press STOP to end the program.</p>
<p>4</p> 	<p>Press START/SET to store the number.</p> <div style="border: 1px solid black; padding: 5px; width: fit-content; margin: 10px auto;">NAME=</div>		

Notes:

- To enter a hyphen in a phone number, press the LOWER key.
- If you make a mistake while programming, press the STOP button, then make the correction.
- To erase a programmed phone number in step 3, press the STOP button when the cursor is positioned on the beginning of the number.
- Confirm that phone numbers and their station names have been correctly stored by printing the telephone number list. See page 48.

To keep a phone number secret

Use this feature to keep a whole phone number or a portion of a phone number secret. When the telephone number list is printed out (see pages 48 and 49), secret numbers will not be printed.

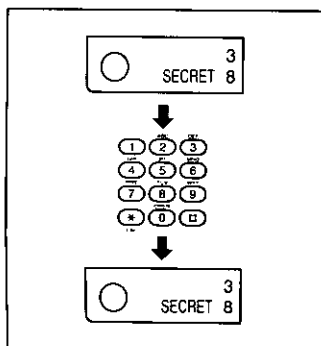

Using the SECRET (direct call station 3) button:

Press **SECRET** before and behind the phone number you wish to keep secret.

Example: The phone number you wish to keep secret is 12345.
Press **SECRET**, 12345 and **SECRET** again.

<A01>=[12345]

Note:

- Pressing **SECRET** once counts as two digits.

Electronic Telephone Directory

The station names stored in memory for automatic dialing are automatically registered in the electronic telephone directory in alphabetical order.

With the electronic telephone directory feature, you can make a fax or voice call by selecting the desired station name on the display.

How to use the electronic telephone directory

To search a station name and make a voice or fax call, proceed as follows.
If you wish to send a fax, insert the documents into the document feeder first.

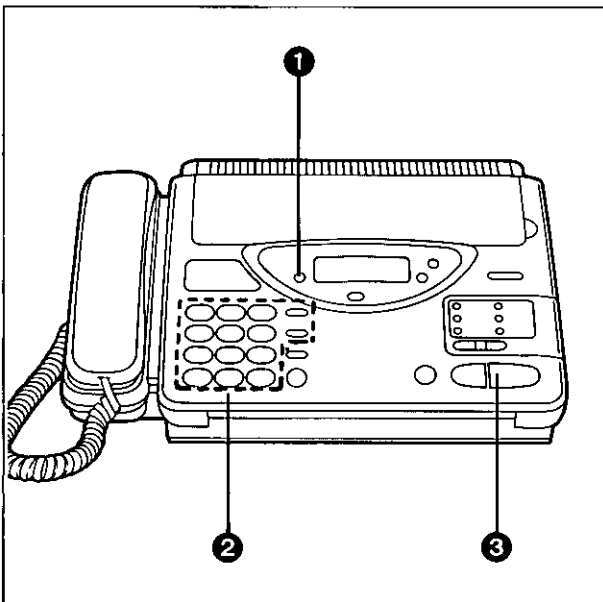

1 Press **DIRECTORY**.

SELECT INDEX

2 ■ Press a dial key to which the initial of a station name is assigned (see Index table).

Example: To search a name with initial "N"
Press 6 repeatedly until the first station name with initial "N" is displayed and press ▼ until the desired name is displayed.

or

■ Press ▲ or ▼ repeatedly until the desired name is displayed.

3 Press **START/SET**.

—The unit will start dialing.

—If a document has been fed into the unit, the transmission will start.

Index table

Dial key	Index	Dial key	Index
1	1	7	P, Q, R, S, 7
2	A, B, C, 2	8	T, U, V, 8
3	D, E, F, 3	9	W, X, Y, Z, 9
4	G, H, I, 4	0	0
5	J, K, L, 5	*	Other symbols
6	M, N, O, 6	#	(not assigned)

Polling

Polling means that you call another facsimile machine to retrieve a document. On the other hand, the documents loaded on your unit can be retrieved only at the request of the calling machines (we call this "Polled" mode).

Polling reception

Make sure that no documents have been fed into your unit and that the other party's machine is ready for your call.

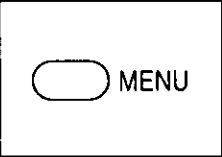
- 1**  Press **MENU** repeatedly until the following is displayed.

4 . POLLING
- 2**  Press **START/SET**.

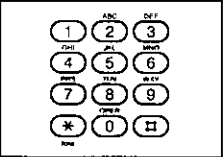
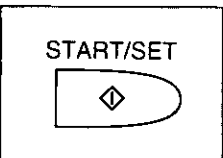
NO. =
- 3**  Enter the phone number by using one-touch dialing, speed dialing or a full number.
- 4**  Press **START/SET**.
—The unit will start polling.

Notes:

- The receiving unit incurs any telephone charges.
- If there is no answer or the line is busy, the unit will automatically redial the number (see item number 7 on page 59).

Polling transmission (Polled)

To let other machines retrieve documents loaded on your unit, proceed as follows.

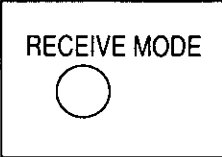
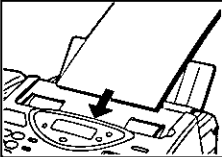
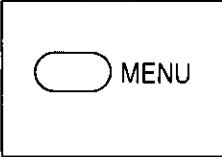
- 1**  Set the unit in the *EXT. TAM, TEL/FAX* or *FAX* mode by pressing **RECEIVE MODE**.
- 2**  Insert the documents **FACE DOWN**.
- 3**  Press **MENU** repeatedly until the following is displayed.

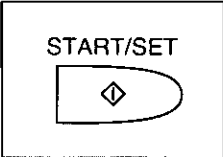
5 . POLLED
- 4**  Press **START/SET**.

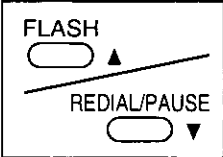
MODE=OFF [▲▼]
- 5**  Press **▲** or **▼** key to select "ON".

MODE=ON [▲▼]

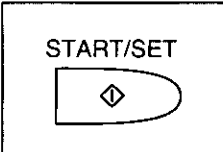
—If you do not require this feature, select "OFF".
- 6**  Press **START/SET**.





POLLED ON

Note:

- When delayed transmission (see page 36) is set to ON, this feature is not available.

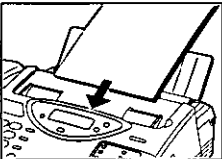
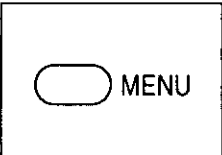
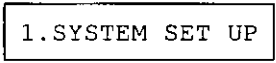
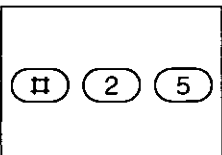
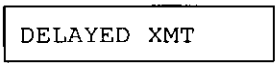
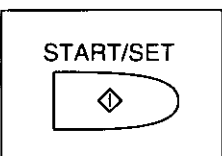
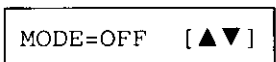
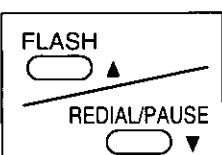
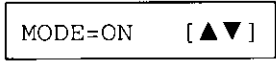
Delayed Transmission

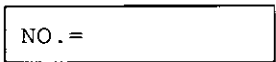
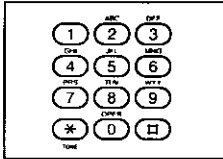
Using a built-in clock, this unit can send documents automatically at a specific time. This allows you to take advantage of low-cost calling hours given by some telephone companies. The delayed transmission can be reserved to take place up to 24 hours.

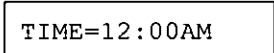
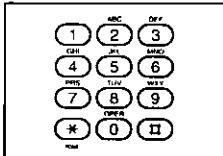
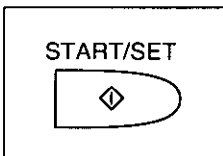
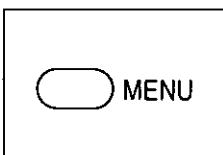
- 1**  Insert the documents **FACE DOWN**.
- 2**  Press **MENU**.

- 3**  Press **#25**.

- 4**  Press **START/SET**.

- 5**  Press **▲** or **▼** to select "ON".

—If you do not require this feature, select "OFF".
- 6**  Press **START/SET**.

- 7**  Enter the phone number using one-touch dialing, speed dialing or a full number.
—You can use the electronic telephone directory (see page 34).
- 8**  Press **START/SET** to store the number.

- 9**  Enter the transmission start time.
Example: 11:00PM
Press **1100**, then press **#** to select PM.
—To select AM, press *****.
- 10**  Press **START/SET** to store the setting.
- 11**  Press **MENU** to end the program.
—When the programmed time has come, the unit will automatically start transmission.

Notes:

- If there is no answer or the line is busy, the unit will automatically redial the number (see item number 7 on page 59).
- You can receive, transmit and copy documents while the delayed transmission is set. To copy or transmit documents, remove documents from the tray and replace them when you have finished.
- If the programmed start time has passed during a power failure, delayed transmission will be attempted soon after the power is restored.
- When polling transmission feature (see page 35) is set to ON, this feature is not available.

Remote Fax Receiving Using an Extension Phone

If you have an extension phone connected to the facsimile unit or connected on the same line, it is possible to receive a fax message into your facsimile unit by using the extension phone. This saves you the trouble of going to the facsimile unit and pressing the START button.

Important:

- This feature is available when you receive a call.
- To activate this feature, use a touch tone telephone as an extension phone and dial the remote fax activation code. The remote fax activation code is set to “**” as a preselected setting.

Using an extension phone

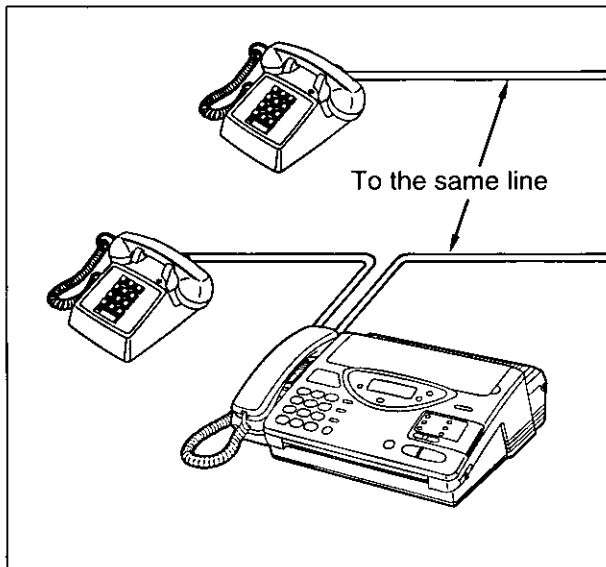

- 1 When a call comes in, lift the handset of the extension phone.
- 2 If a slow beep is heard, or the other party wishes to send you a fax, press the remote fax activation code.
- 3 Replace the handset on the cradle.
—The facsimile unit will activate the fax function to receive documents.

Note:



- The remote fax activation code can be changed. See page 38.

Changing the remote fax activation code

Your code can be from 1 to 4 digits long. The numbers 0 through 9 and character * may be used. (e.g. **, 123, 123*)

Important:

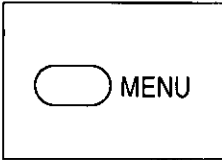
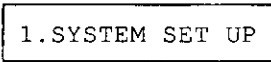
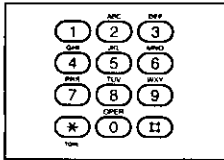
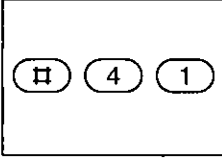
- The remote fax activation code should be different from the remote TAM activation ID (see page 20).

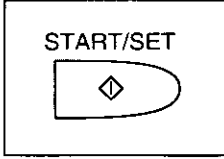
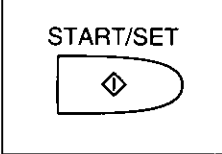
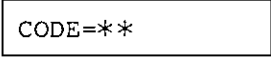
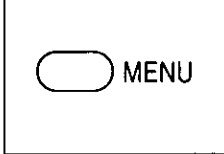
<p>1</p> 	<p>Press MENU.</p> 	<p>4</p> 	<p>Enter the new code number.</p>
<p>2</p> 	<p>Press #41.</p> 	<p>5</p> 	<p>Press START/SET to store the number.</p>
<p>3</p> 	<p>Press START/SET.</p> 	<p>6</p> 	<p>Press MENU to end the program.</p>

Note:

- If the remote fax activation code is set to "0000", the unit does not work properly.

Junk Mail Prohibitor

The feature is effective to prevent fax receptions from unauthorized stations.

With this feature, the unit can receive documents only from the stations whose phone numbers are stored for automatic dialing.

If you wish to receive documents from other stations, advise the caller to call your unit manually and enter your prohibitor ID (see page 40) before initiating transmission.

Important:

- To activate this feature, set the unit in the EXT. TAM, TEL/FAX or FAX mode and let the unit receive documents automatically.
- When in the EXT. TAM or TEL/FAX mode, transmission using the prohibitor ID is available (see page 40).
- When manual reception is used, the documents from any transmitting stations will be received.
- If the transmitting machines has not been programmed with their facsimile telephone numbers, the unit will not be able to receive documents automatically.

Setting the junk mail prohibitor

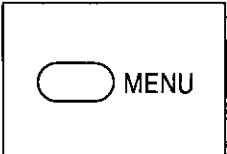
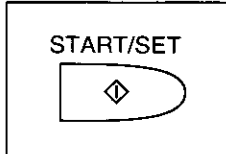
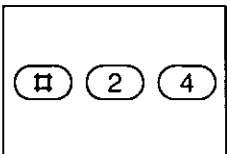
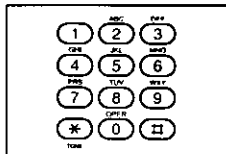
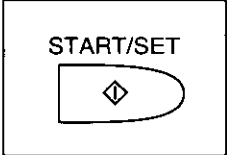
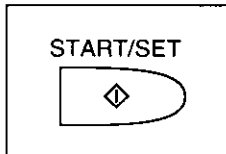
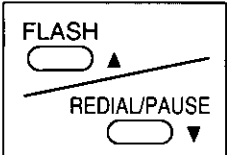
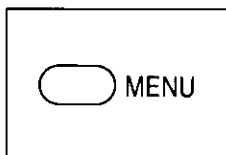
<p>1</p> 	<p>Press MENU.</p> <div style="border: 1px solid black; padding: 5px; width: fit-content; margin: 5px auto;">1.SYSTEM SET UP</div>	<p>5</p> 	<p>Press START/SET to store the setting.</p> <div style="border: 1px solid black; padding: 5px; width: fit-content; margin: 5px auto;">ID=22</div>
<p>2</p> 	<p>Press #24.</p> <div style="border: 1px solid black; padding: 5px; width: fit-content; margin: 5px auto;">JUNK MAIL PROH.</div>	<p>6</p> 	<p>If you wish to change the junk mail prohibitor ID, enter the desired 2-digit number. —0, # and * cannot be used.</p>
<p>3</p> 	<p>Press START/SET.</p> <div style="border: 1px solid black; padding: 5px; width: fit-content; margin: 5px auto;">MODE=OFF [▲▼]</div>	<p>7</p> 	<p>Press START/SET to store the number.</p>
<p>4</p> 	<p>Press ▲ or ▼ to select "ON".</p> <div style="border: 1px solid black; padding: 5px; width: fit-content; margin: 5px auto;">MODE=ON [▲▼]</div> <p>—If you do not require this feature, select "OFF".</p>	<p>8</p> 	<p>Press MENU to end the program.</p>

Note:

- The junk mail prohibitor ID must be different from the first 2 digits of the remote TAM activation ID (see page 20). For example, if the remote TAM activation ID is set to "321", do not use "32" as a junk mail prohibitor ID.

Transmitting documents to your unit with the prohibitor ID _____

If the junk mail prohibitor feature is activated, automatic fax reception from unauthorized stations will not be available. However, in this instance, a caller can transmit documents to your unit manually by entering the prohibitor ID.

Issue the prohibitor ID to callers with priority status.

Important:

- Transmission with the prohibitor ID is activated when your unit is in the EXT. TAM or TEL/FAX mode.

Instructions for caller:

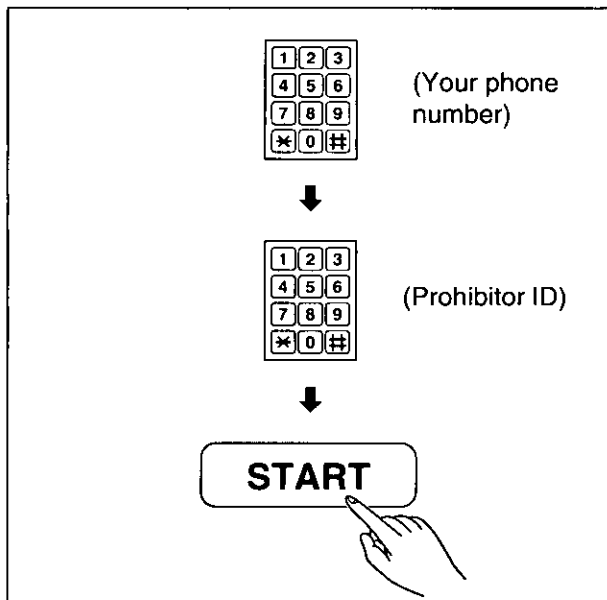

- 1 A caller may call your unit.
- 2 **When your unit is in the EXT. TAM mode:**
They may enter the prohibitor ID while the greeting message is being played or during an incoming message recording mode.

or
When your unit is in the TEL/FAX mode:
They may enter the prohibitor ID while the different ring back tone is heard.
- 3 When a fax tone is heard, they may press their start or transmit button to start the fax transmission.

Special Settings



Logo print position

Your logo, telephone number, date, time and page number will be printed on the transmitted document from your unit in the following manner.

OUT: Outside of the transmitted document's paper size.

IN: Inside of the transmitted document's paper size.

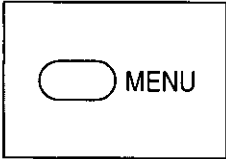
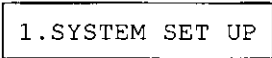
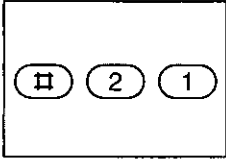
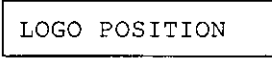
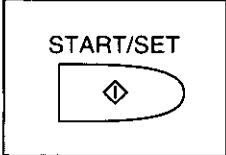
OFF: Not printed.

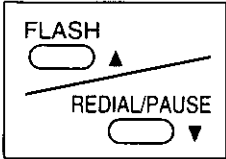
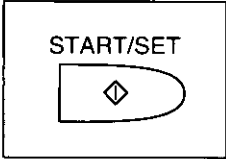
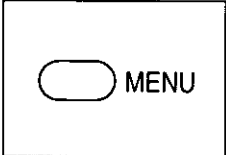
- 1**  Press **MENU**.

- 2**  Press **#21**.

- 3**  Press **START/SET**.

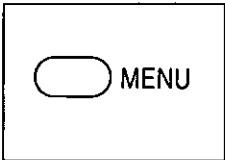
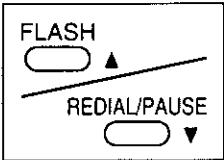
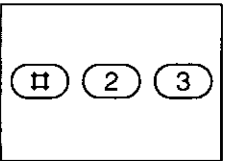
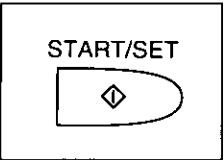
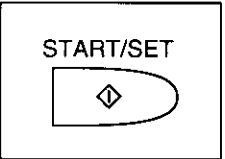
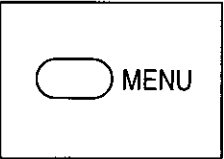
- 4**  Press **▲** or **▼** to select the desired setting.
- 5**  Press **START/SET** to store your selection.
- 6**  Press **MENU** to end the program.

Overseas transmission mode

Use this feature when you have difficulty in transmitting documents overseas.

- | | | | |
|---|--|--|--|
| <p>1</p>  | <p>Press MENU.</p> <div style="border: 1px solid black; padding: 2px; width: fit-content; margin: 5px auto;">1.SYSTEM SET UP</div> | <p>4</p>  | <p>Press ▲ or ▼ to select "ON".</p> <div style="border: 1px solid black; padding: 2px; width: fit-content; margin: 5px auto;">MODE=ON [▲▼]</div> |
| <p>2</p>  | <p>Press #23.</p> <div style="border: 1px solid black; padding: 2px; width: fit-content; margin: 5px auto;">OVERSEAS MODE</div> | <p>5</p>  | <p>—If you do not require this feature, select "OFF".</p> <p>Press START/SET to store your selection.</p> |
| <p>3</p>  | <p>Press START/SET.</p> <div style="border: 1px solid black; padding: 2px; width: fit-content; margin: 5px auto;">MODE=OFF [▲▼]</div> | <p>6</p>  | <p>Press MENU to end the program.</p> <p>—Start transmission procedure (see pages 16 and 17).</p> |

Notes:

- After the transmission has completed, this feature is reset automatically.
- When using this feature, transmission time will increase.

Paper save reception/copy

Use this feature when you wish to save a recording paper during fax reception or copying. With this feature, the unit will reduce the data and print it out in half in length.

Important:

- This feature will not work,
 - when receiving documents sent in fine resolution or other nonstandard resolution.
 - when making a copy in the fine, super fine or half tone resolution.

Sample of paper save print:

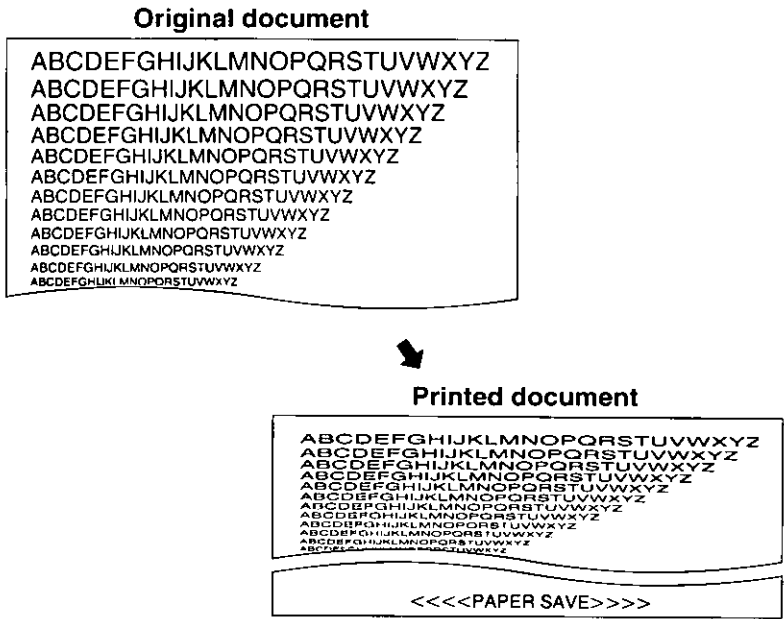

4

To activate this feature, proceed as follows:

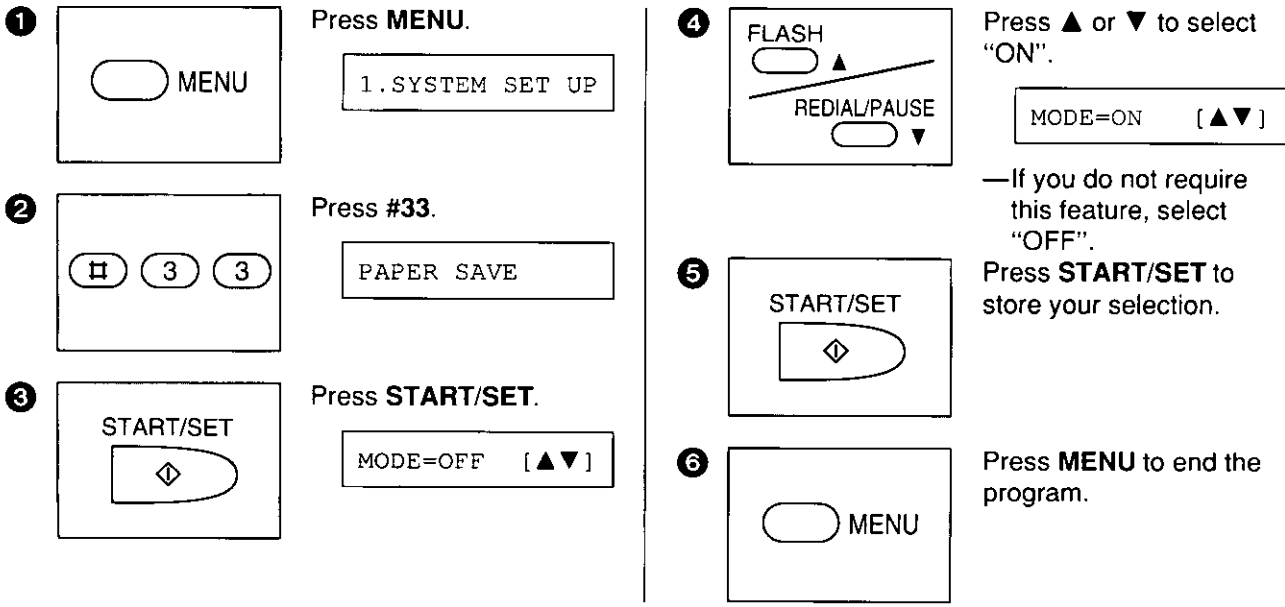

Extension copy

With this feature, the unit will copy a document twice in length. We recommend that you use this feature when you received fax messages in the paper save reception (see page 43) and you wish to enlarge them.

Sample of extended copy:

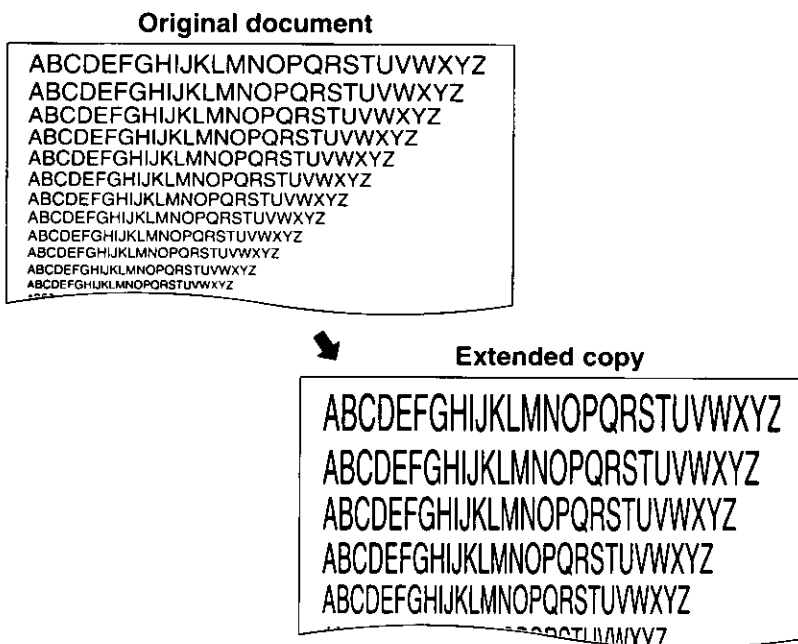

To make an extension copy, proceed as follows:

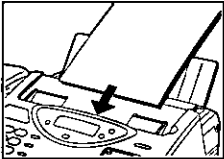
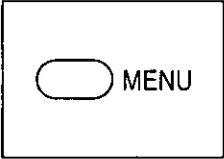
- 1**  Insert the documents
FACE DOWN.
- 2**  Press **MENU**.

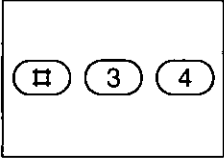
1. SYSTEM SET UP
- 3**  Press **#34**.

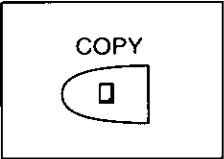
EXTENSION COPY
- 4**  Press **COPY**.

COPYING

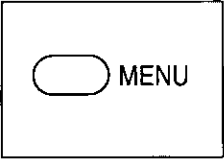
—The unit will start printing.
- 5**  Press **MENU** to end the operation.

Original mode

Use this feature when you need to transmit and copy a document with very faint writing or very dark writing.

The following choices are available:





NORMAL: Used for a document with normal writing.

LIGHT: Used for a document with very faint writing.

DARKER: Used for a document with very dark writing.

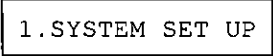
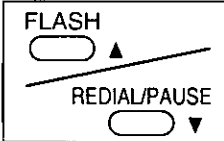
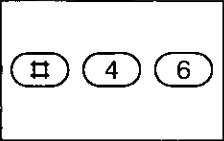
These settings are available in the standard, fine and super fine resolutions.

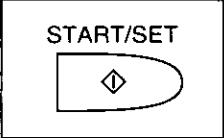
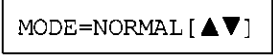
Set this feature before starting transmission or copying by following steps below.



<p>1</p> 	<p>Press MENU.</p> 	<p>4</p> 	<p>Press ▲ or ▼ to select the desired mode.</p>
<p>2</p> 	<p>Press #46.</p> 	<p>5</p> 	<p>Press START/SET to store the setting.</p>
<p>3</p> 	<p>Press START/SET.</p> 	<p>6</p> 	<p>Press MENU to end the program.</p>

Note:

- This feature will return to the normal mode after the transmission or copying has completed.

Resetting the advanced features

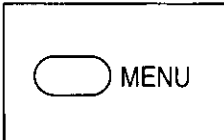
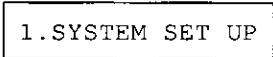
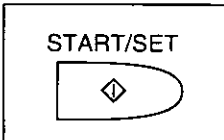
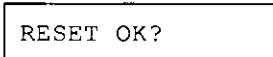
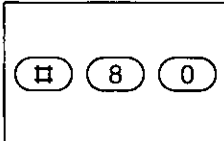
Use this feature to return the advanced features of #21 through #46 (see page 27) to their initial settings.

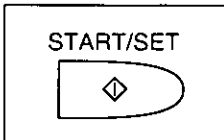
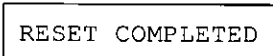
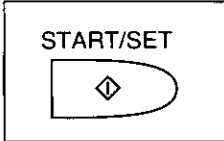
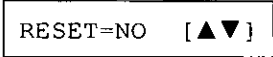
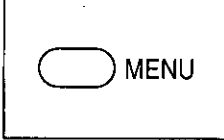
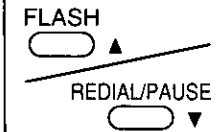
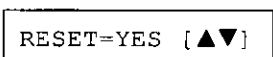
<p>1</p> 	<p>Press MENU.</p> 	<p>5</p> 	<p>Press START/SET.</p> 
<p>2</p> 	<p>Press #80.</p> 	<p>6</p> 	<p>—If you do not require this feature, press the STOP button.</p> <p>Press START/SET again for confirmation.</p> 
<p>3</p> 	<p>Press START/SET.</p> 	<p>7</p> 	<p>Press MENU to end the program.</p>
<p>4</p> 	<p>Press ▲ or ▼ to select "YES".</p> 		

Voice Contact

You can have a voice conversation on the same call after fax transmission or reception is completed. This saves the extra expense and time of making a subsequent telephone call to discuss the information sent over the fax.

Important:

- This feature works only when the other party's unit is equipped with the voice contact/call reservation feature.

Initiating voice contact

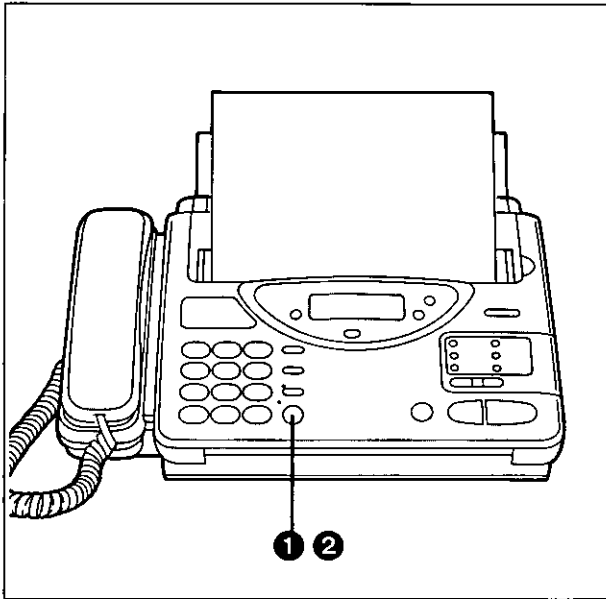

- 1 Press **SP-PHONE** while transmitting or receiving documents.

VOICE STANDBY

—Your unit will call the other party with a distinctive ring.

- 2 When the other party answers, the unit will emit a distinctive ring. While ringing, press **SP-PHONE** again or lift the handset to start speaking.

Notes:

- If you initiate voice contact while transmitting documents, you can speak after all the documents have been transmitted.
- If you initiate voice contact while receiving documents, you can speak after the current page of the documents is received.
- You can initiate the voice contact by lifting the handset during transmission or reception.
- If the other party does not answer, the line will be disconnected automatically.

Receiving a request for voice contact

If the other party initiates voice contact, your unit will emit a distinctive ring after the transmission or reception is completed.

When a distinctive ring is heard, press **SP-PHONE** or lift the handset, then start speaking.

Note:

- If you do not answer within 10 seconds of hearing the distinctive ring, the line will be disconnected automatically.

TONE, FLASH and PAUSE Buttons

TONE button

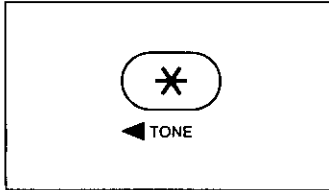

The TONE (*) button is used when your line has a rotary pulse dial service. Pressing the button allows you to change temporarily from pulse to tone mode during a dialing operation. When you hang up, the unit will automatically return to pulse mode.

Note:

- TONE can be stored into a phone number for automatic dialing.

FLASH button

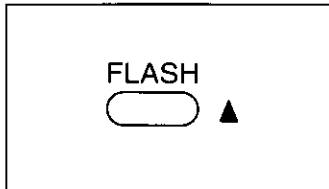

The FLASH button functions as the hookswitch on a regular phone. If you misdial or dial another phone number, press the FLASH button firmly. The call will be terminated and you will hear dial tone. You can then dial the next phone number.

Also pressing the FLASH button allows you to use special features of the host exchange (if connected) or local telephone company services. For further details, contact the supplier or your local telephone companies.

Note:

- FLASH can be stored into a phone number for automatic dialing.

PAUSE button

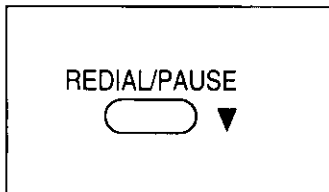

Pressing the REDIAL/PAUSE button causes a dialing delay in the dialing sequence.

Example-1: When your unit is connected to a host exchange, insert a pause as follows to get an outside line.

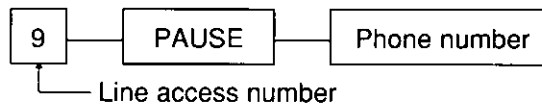

Example-2: If a transmission error occurs frequently when making an overseas transmission, add two pauses at the end of the phone number.

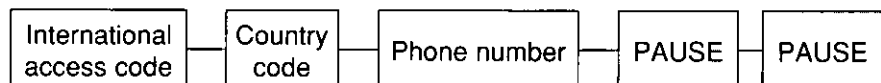

Note:

- PAUSE can be stored into a phone number for automatic dialing.

Printing Reports and Lists

You can get the following reports and lists from your unit. See pages 49 and 50 for sample reports and lists.

Basic Feature List:

This provides you with the current settings of the basic programming features (#01 to #11).

Advanced Feature List:

This gives you a list of the current settings of the advanced programming features (#21 to #80).

Telephone Number List:

This is a list of phone numbers and station names that are stored for one-touch dialing and speed dialing.

Journal Report:

This gives you a record of all transmissions and receptions (up to 35 fax communications). This report is useful for keeping telephone records or for verifying telephone charges.

This report can be printed automatically after every 35 fax communications (see page 51).

Printer Test List:

This allows you to check the print quality of your unit.

If the test pattern has any blurred points or lines or dirty patterns, please clean the thermal head by following the instructions on page 57.

How to print each report/list

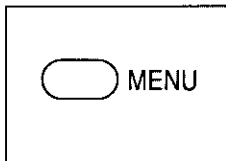
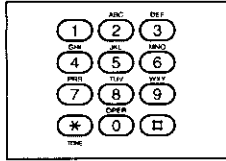
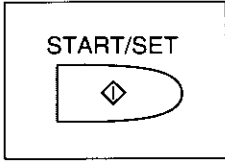
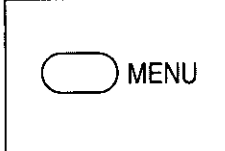
<p>1</p> 	<p>Press MENU repeatedly until the following is displayed.</p> <div style="border: 1px solid black; padding: 5px; width: fit-content; margin: 10px auto;">3.PRINT LIST</div>	<p>For the journal report, press #4.</p> <div style="border: 1px solid black; padding: 5px; width: fit-content; margin: 10px auto;">JOURNAL REPORT</div>
<p>2</p> 	<p>For the basic feature list, press #1.</p> <div style="border: 1px solid black; padding: 5px; width: fit-content; margin: 10px auto;">BASIC LIST</div> <p>For the advanced feature list, press #2.</p> <div style="border: 1px solid black; padding: 5px; width: fit-content; margin: 10px auto;">ADVANCED LIST</div> <p>For the telephone number list, press #3.</p> <div style="border: 1px solid black; padding: 5px; width: fit-content; margin: 10px auto;">TEL NO. LIST</div>	<p>For the printer test list, press #5.</p> <div style="border: 1px solid black; padding: 5px; width: fit-content; margin: 10px auto;">PRINTER TEST</div>
<p>3</p> 	<p>Press START/SET to start printing.</p> <div style="border: 1px solid black; padding: 5px; width: fit-content; margin: 10px auto;">PRINTING</div>	
<p>4</p> 	<p>Press MENU to end the operation.</p>	

Sample reports and lists

Basic feature list

BASIC FEATURE LIST			
NO.	FEATURE	CURRENT SETTING	
#01	SET DATE & TIME	Jan. 01 1994 12:00AM	
#02	YOUR LOGO	Panasonic FAX SYSTEM	
#03	YOUR TELEPHONE NUMBER		
#04	PRINT TRANSMISSION REPORT	ERROR	[ERROR, ON, OFF]
#06	TEL/FAX DELAYED RING	1	[1...4]
#07	FAX RING COUNT	1	[1...4]
#11	REMOTE TAM ACT.	OFF	[ON, OFF]
ID = 11			

Advanced feature list

ADVANCED FEATURE LIST			
NO.	FEATURE	CURRENT SETTING	
#21	LOGO POSITION	OUT	[OUT, IN, OFF]
#22	JOURNAL AUTO PRINT	ON	[ON, OFF]
#23	OVERSEAS MODE	OFF	[ON, OFF]
#24	JUNK MAIL PROHIBITOR	OFF	[ON, OFF]
#25	DELAYED TRANSMISSION	OFF	[ON, OFF]
		ID = 22	
		DESTINATION =	
		START TIME = 12:00AM	
#30	SILENT FAX RECOGNITION RING	3	[3...6]
#33	PAPER SAVE FUNCTION	OFF	[ON, OFF]
#34	EXTERNAL FAX		[ON, OFF]

Telephone number list

TELEPHONE NUMBER LIST			
STATION KEY LIST			
TELEPHONE NUMBER	NAME	TELEPHONE NUMBER	NAME
01 092-123-4567	COMPANY A	06 999-1234	
02 83-555-1234	COMPANY B	07 []	
03 012-999-8877	COMPANY C	08	
04 83P4567		09	
05 987-6543		10	
AUTO KEY LIST			
TELEPHONE NUMBER	NAME	TELEPHONE NUMBER	NAME
00 111-2233*123		11 222-3344	COMPANY D
01 765-4321		12 092-555-6677	COMPANY E
02 345F6789		13	
03 092[]		14	
04		15	
05		16	

Codes in each phone number

*: * has been entered.

P: The pause has been entered.

F: The flash has been entered.

-: The hyphen has been entered.

[]: The secret phone number has been entered.
(The telephone number is not printed.)

5

Journal report

JOURNAL							
Jan. 01 1994 06:05PM							
NO.	OTHER FACSIMILE	START TIME	USAGE TIME	MODE	PAGES	RESULT	*CODE
01	1234567	Jan. 01 11:28AM	01'20	TX	02	OK	
02	9998765	Jan. 01 11:52AM	00'56	TX	01	OK	
03	<< G3 >>	Jan. 01 11:58AM	00'32	RX	01	OK	
04	555556677	Jan. 01 00:19PM	01'48	TX	03	OK	
05	+987 1234	Jan. 01 00:35PM	01'42	RX	03	OK	
06	<S01>	Jan. 01 01:14PM	02'40	TX	05	OK	
07	7776543	Jan. 01 01:27PM	01'03	TX	01	OK	
08	4445566	Jan. 01 02:46PM	01'18	TX	02	OK	
09	<A17>	Jan. 01 03:17PM	00'35	TX	00	COMMUNICATION ERROR	(71)
10	<< G3 >>	Jan. 01 03:19PM	01'21	RX	03	OK	
11	6667788	Jan. 01 03:38PM	02'25	TX	04	OK	
				TX	01	OK	
				TX	02	OK	



- ① Communication mode:
TX...Transmission
RX...Reception
POL.TX...Polling transmission
POL.RX...Polling reception
- ② Number of pages received or transmitted successfully
- ③ Communication result
(For the explanation of communication results, see page 54.)
- ④ Error code (for the service personnel use only)

Printer test list

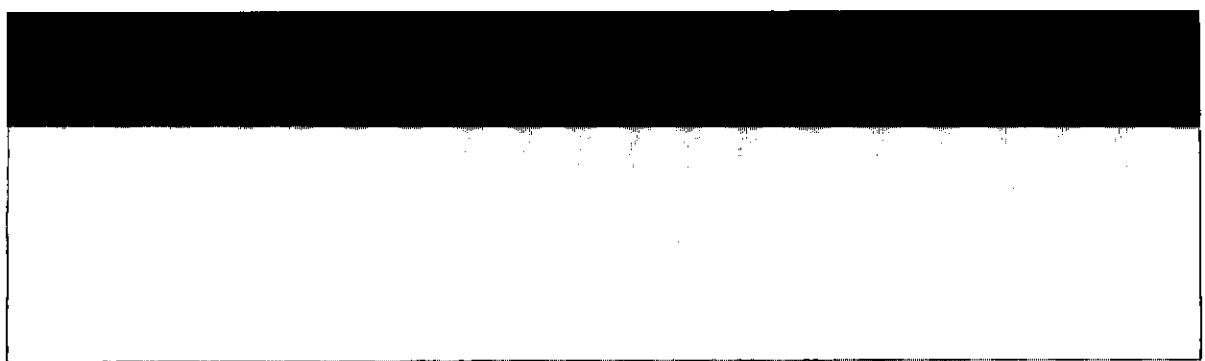



Setting journal auto print

This feature allows the unit to print a record of the last 35 fax communications (transmissions and receptions) automatically.

After printing, memory will clear and the unit will begin to store new data of the journal report.

When this feature is deactivated, the journal report data is stored until the memory becomes full. When memory is full and a new communication takes place, the oldest data will be erased and the newest data will be stored.

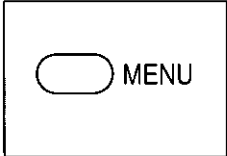
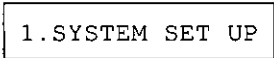
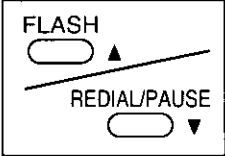
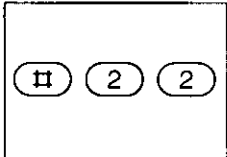
To activate this feature, proceed as follows:

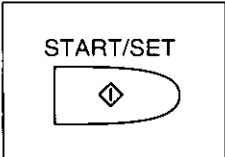
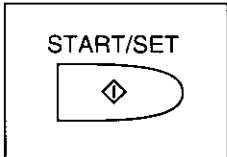
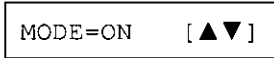
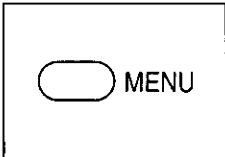
- | | | | | |
|--|--|--|---|---|
| <p>1</p>  | <p>Press MENU.</p> |  | <p>4</p>  | <p>Press ▲ or ▼ to select the desired mode.</p> |
| <p>2</p>  | <p>Press #, then press 22.</p> |  | <p>5</p>  | <p>Press START/SET to store the setting.</p> |
| <p>3</p>  | <p>Press START/SET.</p> |  | <p>6</p>  | <p>Press MENU to end the program.</p> |

Troubleshooting

Error messages on the display

If the unit detects a problem, one of the following messages will appear on the display.

ERROR MESSAGE	CAUSE AND REMEDY
CHECK COVER	<ul style="list-style-type: none">•The top cover is open. Close it.
CHECK DOCUMENT	<ul style="list-style-type: none">•The document is not fed into the unit properly. Re-insert the document. If the misfeeding occurs frequently, clean the document feeder rollers inside the unit (see page 57). Still it remains unsolved, adjust the feeder pressure (see page 56).
CHECK MEMORY	<ul style="list-style-type: none">•Memory (phone numbers, parameters, etc.) has been erased. Re-program them.
MECHA ERROR	<ul style="list-style-type: none">•Mechanical error occurs. Open the cover and re-install the recording paper. Then press the STOP button and close the cover.
NO RESPONSE	<ul style="list-style-type: none">•The receiving unit is busy or out of recording paper. Try again.
OUT OF PAPER	<ul style="list-style-type: none">•The unit ran out of recording paper. Replace it (see page 8).
PAPER JAMMED	<ul style="list-style-type: none">•The recording paper is jammed. Clear the jammed paper (see page 55).
POLLING ERROR	<ul style="list-style-type: none">•The other unit does not provide the polling function. Check the other party.
REMOVE DOCUMENT	<ul style="list-style-type: none">•The document is jammed. Open the cover, remove the jammed document (see page 56) and try again.•Attempted to transmit a document longer than 600 mm (23$\frac{5}{8}$""). Press the STOP button and remove it (see page 56).
TRANSMIT ERROR	<ul style="list-style-type: none">•Transmission error occurs. Try again.
UNIT OVERHEATED	<ul style="list-style-type: none">•The unit is too hot. Leave it as it is and allow it to cool down.

General corrective measures

GENERAL

I cannot make and receive calls.

- The line cord is connected incorrectly or not connected. Confirm the connection (see page 9).

I cannot make calls.

- The setting of the dialing mode is wrong. Check the selector (see page 9).

The unit does not work.

- Disconnect the unit from the telephone line and connect a known working phone. If the known working phone operates properly, call your service personnel to have the unit repaired. If the known working phone does not operate properly, consult your telephone company.

The unit does not ring.

- The ringer volume is set to OFF. Raise it to a suitable level (see page 10).

The REDIAL/PAUSE button does not function properly.

- The button has combination feature of redial and pause. It will redial the last dialed number when it is pressed after hanging up and getting dial tone again (see page 13). If it is pressed after you dial another phone number, the button will function as pause button (see page 47).

While programming, I cannot enter the code or ID number.

- The whole or part of the number you try to enter is same as the other code or ID. Change the number into new one (see pages 20, 38 and 39).

FAX TRANSMISSION

The other party complains that letters on their received document are distorted.

- If your line has special telephone services such as call waiting, the service may have been activated during the fax reception. Connect the unit to a line that does not have such services.
- Another telephone connected to the same line as your unit is connected is hung off. Hang up and try again.

The other party complains that dirty patterns or black line appear on their received documents.

- The glass or rollers on your unit are dirty. Clean them (see page 57).

I cannot make an international fax call.

- Use the overseas transmission mode (see page 42).
- Add two pauses at the end of the phone number (see page 47).

FAX RECEPTION

I cannot receive documents automatically.

- The receive mode is set to TEL. Set the receive mode to EXT. TAM, TEL/FAX or FAX.
- The time to answer the call may be too long. Decrease the number of rings (see pages 23 and 24).

Recording image is faint.

- The sender transmitted a faint document. Request them to transmit a clearer copy of the document.
- The thermal head is dirty. Clean it (see page 57).

RECEPTION IN EXT. TAM MODE

I cannot receive documents automatically.

- Your greeting message on the answering machine may be too long. Shorten the message (up to 10 seconds) or ask the other party to press your remote fax activation code and then start transmission (see page 37).
- Set the number of rings to one or two on the answering machine.
- The silent detection feature is set to OFF. Set it to ON (see page 21).

I cannot receive voice messages.

- Confirm that the answering machine is turned on or connected to the unit properly.
- Set the number of rings to one or two on the answering machine.

RECEPTION IN EXT. TAM MODE (cont.)

I cannot retrieve messages remotely from the answering machine.

—Your remote TAM activation code on the answering machine may be same as your remote fax activation code or junk mail prohibitor ID. Set a different number in each code or ID. Also set the same remote TAM activation code as stored on the answering machine into the unit's memory (see page 20).

The greeting message on the answering machine stops halfway and the caller cannot leave a voice message.

—Make sure that the greeting message does not have a silent pause longer than 4 seconds. If so, re-record the greeting message.

When I tried to operate the answering machine remotely, the line was disconnected after pressing the remote access code.

—The code may include # which is used for some features provided by the telephone company. Change the code on the answering machine into another number which does not include #, then program the same code into the facsimile unit (see page 20).

COPYING

Dirty patterns or black line appear on the copied documents.

—The glass or rollers on your unit are dirty. Clean them (see page 57).

Copied image is distorted.

—The thermal head is dirty. Clean it (see page 57).

Explanation of communication result on the report _____

When trouble occurs, the following messages may be printed on the transmission report and the journal report.

PRINTED MESSAGE

MEANING

COMMUNICATION ERROR:	●Transmission or reception error occurred. Try again or check the other party.
DOCUMENT JAMMED:	●A document was jammed. Remove the jammed document (see page 56).
JUNKMAIL PROH. REJECT	●The unit rejected fax reception when the junk mail prohibitor is activated.
NO DOCUMENT:	●The document was not fed into the unit properly.
NO RESPONSE:	●The receiving unit is busy or out of recording paper. Try again.
PAPER JAMMED:	●The recording paper was jammed.
PAPER OUT:	●The unit was out of recording paper.
PRESSED THE STOP KEY:	●The fax communication was interrupted because the STOP button was pressed.
PRINTER OVERHEATED:	●Printer was overheated.
THE COVER WAS OPENED:	●The top cover was open.
OK:	●Fax communication was successful.

Clearing a recording paper jam

When the unit does not eject a recording paper during reception or copying, the recording paper has jammed. Remove the jammed paper by following the steps below.

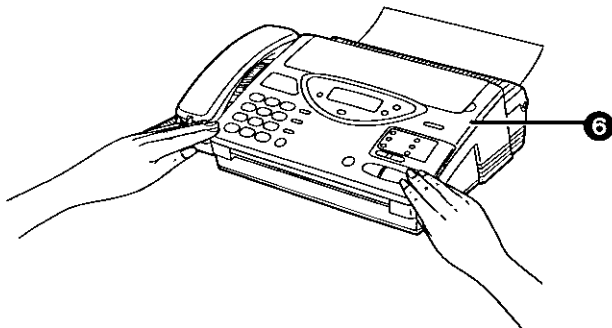
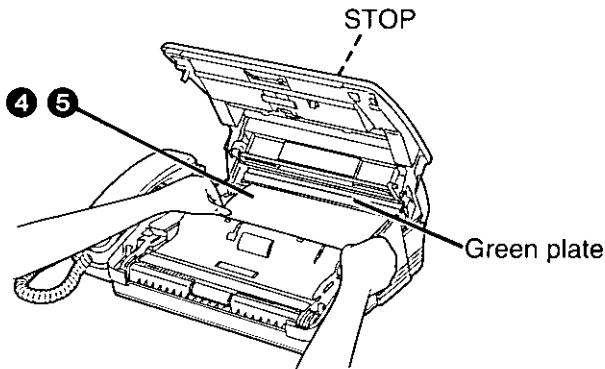
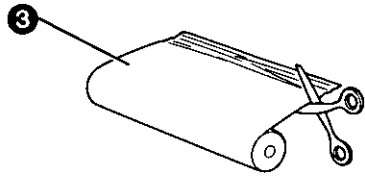
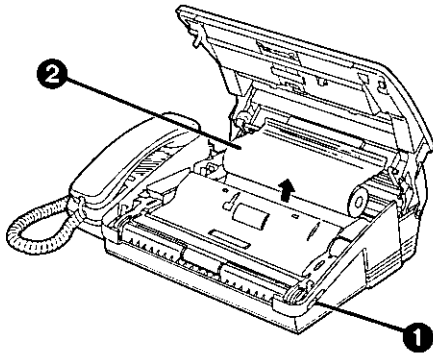

- 1 Slide the lever forward to open the top cover.
- 2 Remove the jammed paper carefully.
- 3 Cut off the wrinkled portion.
- 4 Replace the recording paper roll in the proper direction.
—Make sure that there is no slack in the paper roll.
- 5 Insert the leading edge of the paper under the green plate.
—If the recording paper cannot be inserted, press the STOP button to reset the paper cutter and insert the paper again.
- 6 Close the top cover carefully by gently pushing down on both ends.

Clearing a document jam

When an original document becomes jammed, remove the jammed document by following the steps below.

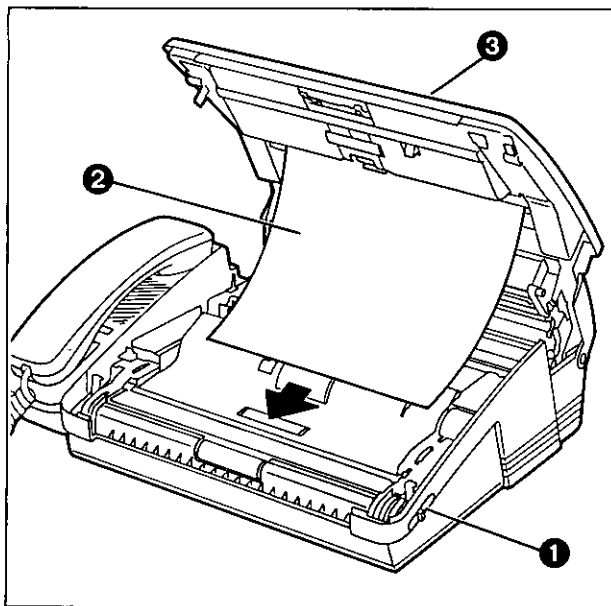

- 1 Slide the top cover open lever forward to open the top cover.
- 2 Remove the jammed document carefully.
- 3 Close the cover carefully by pushing down on both ends gently.

Adjusting the feeder pressure

If misfeeding of documents, such a multiple feeding or no feeding, occurs frequently, try to adjust the feeder pressure by following the steps below.

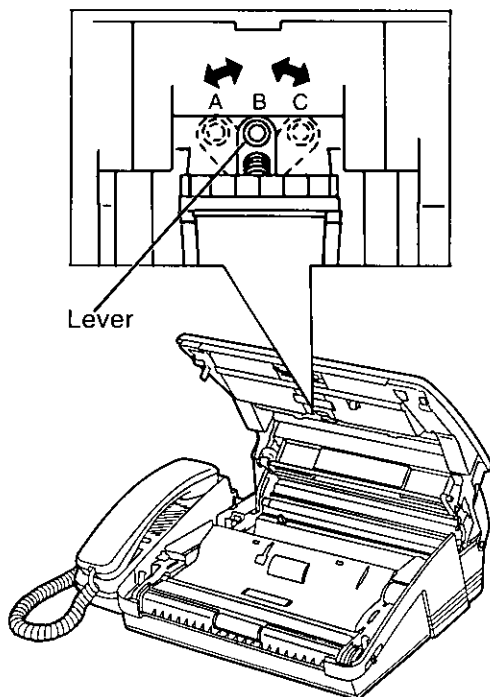

- 1 Open the top cover.
- 2 Shift the position of the lever by using an instrument with a pointed end, like a clip or ball-point pen.

Position A: The case of no feeding
Position B: Standard position
Position C: The case of multiple feeding
- 3 Close the top cover carefully by gently pressing down on both ends.

Maintenance

Cleaning the document feeder unit

When the misfeeding occurs frequently or when dirty patterns or black bands appear on a copied or transmitted document, clean the sub roller, the document feeder rollers and the glass by following the steps below.

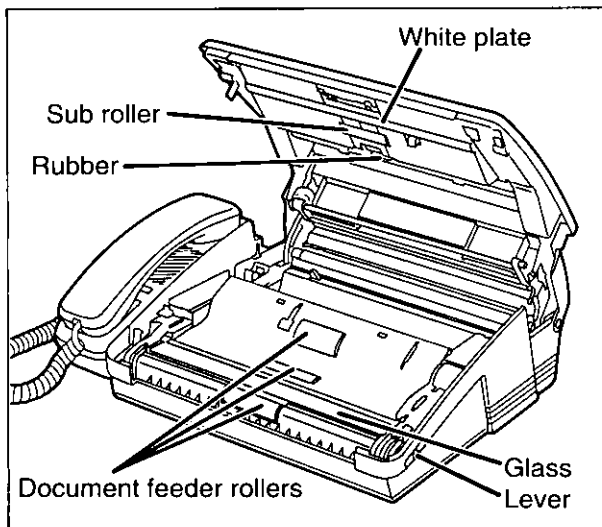

- 1 Disconnect the power cord and the telephone line cord.
- 2 Slide the lever forward to open the top cover.
- 3 Clean the rubber, the sub roller and the document feeder rollers with a cloth moistened with isopropyl rubbing alcohol, then dry thoroughly.
- 4 Clean the glass and the white plate with a dry soft cloth.
- 5 Close the top cover carefully by pushing down on both ends gently.
- 6 Connect the power cord and telephone line cord.

Cleaning the thermal head

If dirty patterns or black bands appear on a copied or received document, clean the thermal head by following the steps below.

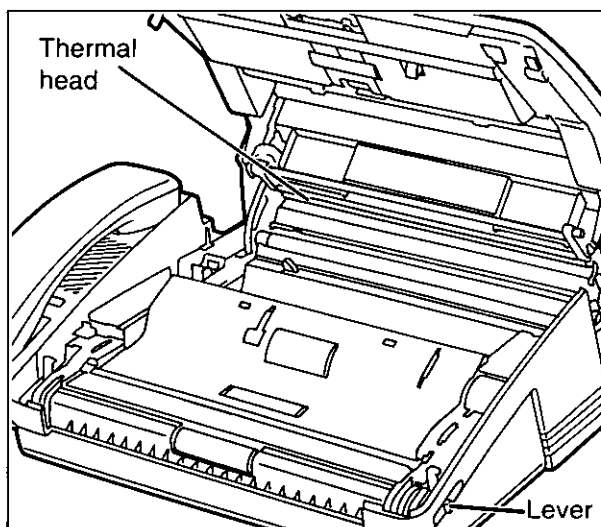

- 1 Disconnect the power cord and the telephone line cord.
- 2 Slide the lever forward to open the top cover.
- 3 Remove the recording paper roll from the unit.
- 4 Clean the thermal head with a cloth moistened with isopropyl rubbing alcohol, then dry thoroughly.
- 5 Re-install the recording paper roll, then close the top cover carefully by pushing down on both ends gently.
- 6 Connect the power cord and telephone line cord.

Note:

- To prevent malfunction due to static electricity, do not use a dry cloth and do not touch the thermal head directly with your finger.

Important Safety Instructions

When using this unit, basic safety precautions as below should always be followed to reduce the risk of fire, electric shock, or personal injury.

1. Read and understand all instructions.
2. Follow all warnings and instructions marked on this unit.
3. Unplug this unit from wall outlets before cleaning. Do not use liquid or aerosol cleaners. Use a damp cloth for cleaning.
4. Do not use this unit near water, for example, near a bath tub, wash bowl, kitchen sink, or the like.
5. Install this unit securely on a stable surface. Serious damage may result if the unit falls.
6. Do not cover slots and openings of the unit, for they are provided for ventilation and protection against overheating. Never place the unit near radiators, in/or a place where proper ventilation is not provided.
7. Use only the power source as marked on the unit. If you are not sure of the type of the power supply to your home, consult your dealer or local power company.
8. Do not place objects on the power cord. Install the unit where no one can step on the cord.
9. Do not overload wall outlets and extension cords as this can result in the risk of fire or electric shock.
10. Never push any objects into this unit through slots as they may result in risk of fire or electric shock. Never spill any liquid on the unit.
11. To reduce the risk of electric shock, do not disassemble this unit, but take it to a qualified serviceman when some service or repair work is required. Opening or removing covers may expose you to dangerous voltages or other risks. Incorrect reassembly can cause electric shock when the appliance is subsequently used.
12. Unplug this unit from the wall outlet and refer servicing to qualified service personnel under the following conditions:
 - A. When the power supply cord or plug is damaged or frayed.
 - B. If liquid has been spilled into the unit.
 - C. If the unit has been exposed to rain or water.
 - D. If the unit does not work normally by following the operating instructions. Adjust only controls covered by the operating

instructions, for improper adjustment may require extensive work by a qualified technician.

- E. If the unit has been dropped or damaged.
 - F. If the unit exhibits a distinct change in performance.
13. During thunderstorms, avoid using telephones except cordless types. There may be a remote risk of electric shock from lightning.
 14. Do not use this unit to report a gas leak in the vicinity of it.

SAVE THESE INSTRUCTIONS

INSTALLATION:

1. Never install telephone wiring during a lightning storm.
2. Never install telephone jacks in wet locations unless the jack is specifically designed for wet locations.
3. Never touch uninsulated telephone wires or terminals unless the telephone line has been disconnected at the network interface.
4. Use caution when installing or modifying telephone lines.

WARNING:

To prevent fire or shock hazard, do not expose this product to rain or any type of moisture.

Other Information

- Keep the unit away from electrical noise-generating devices, such as fluorescent lamps and motors.
- The unit should be kept free from dust, moisture, high temperature, and vibration.
- The unit should not be exposed to direct sunlight.
- Do not place heavy objects on top of this unit.
- Do not use benzine, thinner, or any abrasive powder, to clean the cabinet. Wipe it with a soft cloth.
- Do not damage the power cord.
Do not touch the plug with wet hands.

Accessory Order Information

Use the following type of recording paper for replacement. For accessory order, call toll free 1-800-332-5368.

Parts No.	Description	Comment
KX-A116	Standard Thermal Recording Paper	216 mm×50 m (8½"×164') roll
KX-A106	Standard Thermal Recording Paper	216 mm×30 m (8½"×98') roll
KX-A125	Super Thermal Recording Paper (Plain paper like)	216 mm×30 m (8½"×98') roll

Specifications

1. **Applicable Lines:** Public Switched Telephone Network
2. **Document Size:** Max. 216 mm (8½") in width
Max. 600 mm (235⅞") in length
3. **Effective Scanning Width:** 208 mm (8⅜")
4. **Printing Paper Size:** (See Accessory Order Information on this page)
5. **Effective Printing Width:** 208 mm (8⅜")
6. **Transmission Time*:** Approx. 15 sec/page (Original mode)
Approx. 30 sec/page (G3 Normal mode)
7. **Fax Auto Redial:** Up to 5 times
8. **Telephone Auto Redial:** Up to 14 times
9. **Scanning Density:** Horizontal 8 pels/mm (203 pels/inch)
Vertical 3.85 lines/mm (98 lines/inch)—Standard
7.7 lines/mm (196 lines/inch)—Fine/Halftone
15.4 lines/mm (392 lines/inch)—Superfine
10. **Scanner Type:** CCD image sensor
11. **Printer Type:** Thermal printing
12. **Data Compression System:** Modified Huffman (MH), Modified READ (MR)
13. **Modem Speed:** 9600/7200/4800/2400 bps; Automatic Fallback
14. **Operating Environment:** 5–35°C (41–95°F), 45%–85% RH
15. **Dimensions (H×W×D):** 122×362×287 mm (4⅓⅙"×14¼"×11⅝")
16. **Mass (Weight):** Approx. 3.9 Kg (8.6 lb.)
17. **Power Consumption:** Transmission: Approx. 15 W / Reception: Approx. 35 W
Copy: Approx. 40 W / Standby: Approx. 5 W
Maximum: Approx. 100 W
18. **Power Supply:** 120 V AC, 60 Hz

*Transmission Time: Transmission times apply to text data using ITU-T No. 1 test chart, between the same machine models at maximum modem speed. Transmission times vary in actual usage.

FCC Information

If required by the telephone company, inform them of the following.

- FCC Registration No.: (found on the rear side of the unit)
- Ringer Equivalence No.: (found on the rear side of the unit)
- The particular telephone line to which the equipment is connected.

This unit must not be connected to a coin operated line. If you are on a party line, check with your local telephone company.

Ringer Equivalence Number (REN):

This REN is useful in determining the quantity of devices you may connect to your telephone line and still have all of those devices ring when your telephone number is called. In most but not all areas, the sum of the REN's of all devices connected to one line should not exceed five (5.0). To be certain of the number of devices you may connect to your line, as determined by the REN, you should contact your local telephone company to determine the maximum REN for your calling area.

In the event that terminal equipment causes harm to the telephone network, the telephone company should notify the customer, if possible, that service may be stopped. However, where prior notice is impractical, the company may temporarily cease service providing that they:

- a) Promptly notify the customer.
- b) Give the customer an opportunity to correct the problem with their equipment.
- c) Inform the customer of the right to bring a complaint to the Federal Communication Commission pursuant to procedures set out in FCC Rules and Regulations Subpart E of Part 68.

The Telephone Company may make changes in its communications facilities, equipment operations, or procedures where such action is reasonably required in the operation of its business and is not inconsistent with the rules and regulations in FCC Part 68. If such changes can be reasonably expected to render any customer terminal equipment incompatible with telephone company communications facilities, or require modification

or alteration of such terminal equipment, or otherwise materially affect its use or performance, the customer shall be given adequate notice in writing, to allow the customer an opportunity to maintain uninterrupted service.

CAUTION:

Any unauthorized changes or modifications to this equipment could void the user's authority to operate this device.

When programming emergency numbers and/or making test calls to emergency numbers:

1. Remain on the line and briefly explain to the dispatcher the reason for the call before hanging up.
2. Perform such activities in the off-peak hours; such as early morning or late evenings.

This telephone provides magnetic coupling to hearing aids.

Note:

This equipment has been tested and found to comply with the limits for a Class B digital device, pursuant to Part 15 of the FCC Rules. These limits are designed to provide reasonable protection against harmful interference in a residential installation. This equipment generates, uses, and can radiate radio frequency energy and, if not installed and used in accordance with the instructions, may cause harmful interference to radio communications. However, there is no guarantee that interference will not occur in a particular installation. If this equipment does cause harmful interference to radio or television reception, which can be determined by turning the equipment off and on, the user is encouraged to try to correct the interference by one or more of the following measures:

- Reorient or relocate the receiving antenna.
- Increase the separation between the equipment and receiver.
- Connect the equipment into an outlet on a circuit different from that to which the receiver is connected.
- Consult the dealer or an experienced radio/TV technician for help.

Limited Warranty

PANASONIC PERSONAL FACSIMILE Limited Warranty

Matsushita Consumer Electronics Company or Panasonic Sales Company (collectively referred to as "The warrantor"), will repair this product with new or refurbished parts, free of charge, in the U.S.A. or Puerto Rico for one (1) year from the date of original purchase in the event of a defect in materials or workmanship.

Batteries (when applicable)—New rechargeable batteries in exchange for defective rechargeable batteries for ten (10) days from the date of original purchase. Non-rechargeable batteries are not warranted.

Carry-in or mail-in service in the U.S.A. can be obtained during the warranty period from a Matsushita Services Company (MSC) Factory Servicenter listed in the Servicenter Directory. Carry-in or mail-in service in Puerto Rico can be obtained during the warranty period by calling the telephone numbers listed in the Servicenter Directory.

This warranty is extended only to the original purchaser. A purchase receipt or other proof of date of original purchase will be required before warranty performance is rendered.

This warranty only covers failures due to defects in materials or workmanship which occur during normal use. It does not cover damage which occurs in shipment or failures which are caused by products not supplied by the warrantor or failures which result from accident, misuse, abuse, neglect, mishandling, misapplication, alteration, faulty installation, modification, or service by anyone other than an MSC Factory Servicenter or an authorized MSC Servicenter or damage that is attributable to Acts of God, including, but not limited to, line surges.

LIMITS AND EXCLUSIONS

There are no express warranties except as listed above.

THE WARRANTOR SHALL NOT BE LIABLE FOR SPECIAL, INCIDENTAL, CONSEQUENTIAL OR PUNITIVE DAMAGES, INCLUDING, WITHOUT LIMITATION, LOSS OF GOODWILL, PROFITS OR REVENUE, LOSS OF USE OF THIS PRODUCT OR ANY ASSOCIATED EQUIPMENT, COST OF SUBSTITUTE EQUIPMENT, DOWNTIME COSTS, OR CLAIMS OF ANY PARTY DEALING WITH BUYER FOR SUCH DAMAGES, RESULTING FROM THE USE OF THIS PRODUCT OR ARISING FROM BREACH OF WARRANTY OR CONTRACT, NEGLIGENCE, OR ANY OTHER LEGAL THEORY.

ALL EXPRESS AND IMPLIED WARRANTIES, INCLUDING THE WARRANTIES OF MERCHANTABILITY AND FITNESS FOR A PARTICULAR PURPOSE, ARE LIMITED TO THE APPLICABLE WARRANTY PERIOD SET FORTH ABOVE.

Some states do not allow the exclusion or limitation of consequential damages, or limitations on how long an implied warranty lasts, so the above exclusions or limitations may not apply to you.

This warranty gives you specific legal rights, and you may also have other rights which vary from state to state.

If a problem with this product develops during the warranty period, you may contact your dealer or the MSC Factory Servicenter or authorized MSC servicenter. If the problem is not handled to your satisfaction, write to the Customer Satisfaction Center at the address indicated on the Servicenter Directory.

Index

A	Advanced feature list	48	O	One-touch dialing	12, 17, 32
	Automatic dialing	12, 17, 32		Original mode	45
B	Basic feature list	48		Overseas transmission mode	42
C	Cleaning	57	P	Paper save	43
	COPY	25		PAUSE	47
D	Date and time	30		Polled	35
	Delayed transmission	36		Polling	35
	DELETE	29		Printer test list	48
	Dial keypad	28	R	RECEIVE MODE	11
	Dialing mode	9		REDIAL/PAUSE	13
	Direct call station keys	12, 17, 29, 32		Remote fax activation code	37, 38
	DIRECTORY	12, 17, 34		Remote TAM activation ID	20
E	Electronic telephone directory	34		RESOLUTION	15
	Error messages	52		Ringer volume	10
	Extension copy	44	S	SECRET	33
	EXT. TAM mode	11, 18		SET DEFAULT	45
F	FAX mode	11, 24		Silent detection	21
	FAX ring	24		Silent fax recognition ring	23
	Feeder pressure	56		SPACE	29
	FLASH	12, 47		Speaker volume	10
H	Handset volume	10		Speed dialing	12, 17, 33
	HELP	3		SP-PHONE	12, 46
I	INSERT	29		START/SET	16, 20
J	Journal auto print	51		STOP	16
	Journal report	48	T	TEL mode	11
	Junk mail prohibitor	39		TEL/FAX mode	11, 22
	Junk mail prohibitor ID	39, 40		TEL/FAX ring	23
L	Logo position	41		Telephone number list	48
	LOWER	12, 17, 32		TONE	47
M	MENU	20, 30, 35, 48		TONE/PULSE	9
	MUTE	13		Transmission report	31
			V	VOLUME	10
			Y	Your logo	30
				Your telephone number	31

FAX CORRESPONDENCE

TO: _____ DATE: _____

FROM: _____ OUR TEL. NO.: _____

We have Panasonic personal facsimile and a telephone answering machine is connected. So you can send both documents and voice-messages on the same call.

Leaving a voice-message and transmitting a document

1. Dial our phone number.
 - Our telephone answering machine will play the greeting message.
2. Leave your message after the long beep.
3. Press your “*” (asterisk) button **twice** to activate the fax reception.
 - A fax tone will sound.
4. Start transmission to send a fax.

Transmitting a document only

1. Dial our phone number.
 - Our telephone answering machine will play the greeting message.
2. Press your “*” button **twice** while the greeting message is being played.
 - A fax tone will sound.
3. Start transmission to send a fax.

Transmitting a document from a rotary (pulse) phone

1. Dial our phone number.
 - Our telephone answering machine will play the greeting message.
2. Start transmission to send a fax while the greeting message is being played.

Notes:

- If you wish to receive voice messages and documents automatically, the following preparations are necessary.
 - Connect a telephone answering machine to the unit and activate the answering function.
 - Set the unit in EXT. TAM mode.
- “*” button **twice** is called remote fax activation code (see page 38). If you change it into another one, inform callers of pressing the code.

Speed dialer list

Station No.	Name/Phone No.	Station No.	Name/Phone No.
00		11	
01		12	
02		13	
03		14	
04		15	
05		16	
06		17	
07		18	
08		19	
09		20	
10		21	

Speed dialer list

Station No.	Name/Phone No.	Station No.	Name/Phone No.
00		11	
01		12	
02		13	
03		14	
04		15	
05		16	
06		17	
07		18	
08		19	
09		20	
10		21	

Servicenter Directory

PRODUCT INFORMATION • OPERATION ASSISTANCE • LITERATURE REQUESTS • DEALER LOCATIONS

DIAL TOLL FREE: 1-800-HELP-FAX

Customer Satisfaction Center 2F-3, One Panasonic Way, Secaucus, NJ 07094 (Headquarters)
201-348-9090 (9:00am–8:00pm Monday–Friday, EST)

AUTHORIZED SERVICENTERS • PARTS DISTRIBUTOR LOCATIONS

To locate an independent authorized servicenter or parts distributor in your area, within the USA dial toll free **1-800-545-2672**, 24 hours a day, 7 days a week.

PRODUCT REPAIRS *Factory Servicenters*

<p>CALIFORNIA 6550 Katella Avenue Cypress, CA 90630 Phone (714) 373-7425 Fax (714) 894-8534</p> <p>800 Dubuque Avenue So. San Francisco, CA 94080 Phone (415) 871-6373 Fax (415) 871-6840</p> <p>20201 Sherman Way Suite 102 Canoga Park, CA 91306 Phone (818) 709-1775 Fax (818) 709-2165</p> <p>3878 Ruffin Road Suite A San Diego, CA 92123 Phone (619) 560-9200 Fax (619) 560-1831</p> <p>COLORADO 1640 South Abilene Suite D Aurora, CO 80012 Phone (303) 752-2024 Fax (303) 752-0610</p> <p>FLORIDA 3700 North 29th Avenue Suite 102 Hollywood, FL 33020 Phone (305) 925-2880 Fax (305) 925-5224</p> <p>4710 Eisenhower Boulevard Suite A1 Tampa, FL 33634 Phone (813) 884-4746 Fax (818) 886-4564</p>	<p>GEORGIA 4245 International Boulevard Suite C Norcross, GA 30093 Phone (404) 717-6880 Fax (404) 717-6668</p> <p>HAWAII 99-859 Iwaiwa Street Aiea, Hawaii 96701 Phone (808) 488-4369 Fax (808) 486-4369</p> <p>ILLINOIS *1703 North Randall Road Elgin, IL 60123 "12:30 to 4:30, Mon-Fri" Phone (708) 468-5466 Fax (708) 468-5465</p> <p>9060 Golf Road Niles, IL 60714 Phone (708) 299-1700 Fax (708) 299-1710</p> <p>MARYLAND Sulphur Springs Business Center 1638 Sulphur Springs Road Baltimore, MD 21227 Phone (410) 242-2607 Fax (410) 247-3047</p> <p>MASSACHUSETTS 60 Glacier Drive, Suite G Westwood, MA 02090 Phone (617) 329-4280 Fax (617) 329-0586</p> <p>*pick-up/drop-off only</p>	<p>MICHIGAN 37048 Van Dyke Avenue Sterling Heights, MI 48312 Phone (810) 939-2060 Fax (810) 939-2638</p> <p>MINNESOTA 7850-12th Avenue South Airport Business Center Bloomington, MN 55425 Phone (612) 854-8624 Fax (612) 854-2089</p> <p>MISSOURI 11982 Dorsett Road Maryland Heights, MO 63043 Phone (314) 739-5301 Fax (314) 739-3631</p> <p>OHIO 2236 Waycross Road Cincinnati, OH 45240 Phone (513) 851-4180 Fax (513) 851-8443</p> <p>PENNSYLVANIA 2221 Cabot Boulevard West Suite B Langhorne, PA 19047 Phone (215) 741-0661 Fax (215) 741-0521</p> <p>Campbell's Run Business Center 500 Business Center Drive Pittsburgh, PA 15205 Phone (412) 788-2174 Fax (412) 788-2176</p>	<p>TENNESSEE 919-8th Avenue South Nashville, TN 37203 Phone (615) 244-4434 Fax (615) 244-6713</p> <p>TEXAS 7482 Harwin Drive Airport Business Center Houston, TX 77036 Phone (713) 781-1528 Fax (713) 781-0643</p> <p>13615 Welch Road Suite 101 Farmers Branch, TX 75244 Phone (214) 385-1975 Fax (214) 960-7626</p> <p>WASHINGTON 20425-84th Avenue South Kent, WA 98032 Phone (206) 872-7922 Fax (206) 872-0918</p>
Service in Puerto Rico			
<p>Matsushita Electric of Puerto Rico, Inc. Panasonic Sales Company/ Factory Servicenter</p> <p>Ave. 65 de Infantería, Km. 9.5 San Gabriel Industrial Park Carolina, Puerto Rico 00985 Phone (809) 750-4300 Fax (809) 768-2910</p>			

REPAIR INQUIRIES *Regional Customer Care Department*

<p>EAST (PCE) 2221 Cabot Boulevard West Suite A Langhorne, PA 19047 Phone (215) 741-0676 Fax (215) 750-6492</p> <p>Covers: CT, DE, ME, MD, MA, NH, NJ, NY, PA, RI, VT, VA, DC, WV</p>	<p>EAST (PCE) 1854 Shackelford Court Suite 4105 Norcross, GA 30093 Phone (404) 717-6860 Fax (404) 717-6678</p> <p>Covers: AL, FL, GA, MS, NC, SC, TN</p>	<p>CENTRAL (PCC) 1703 North Randall Road Elgin, IL 60123 Phone (708) 468-5530 Fax (708) 468-5528</p> <p>Covers: AR, IL, IN, IA, KS, KY, LA, MI, MN, MO, NE, ND, OK, SD, TX, WI, OH</p>	<p>WEST (PCW) 6550 Katella Avenue Cypress, CA 90630 Phone (714) 373-7440 Fax (714) 373-7447</p> <p>Covers: AK, AZ, CA, CO, ID, MT, NV, NM, OR, UT, WA, WY, HI</p>
---	--	--	---

ACCESSORY PURCHASES

1-800-332-5368 (Consumer Orders Only)
Matsushita Services Company Box 01, 545 Tollgate Road Suite C, Elgin, IL 60123
(8:00am–7:30pm Monday–Thursday; 8:00am–5:00pm Friday; 9:00am–12:30pm Saturday; CST)
(Visa, Mastercard, Discover card, Check or Money Order)

(940905)

FAX ADVANTAGE PROGRAM

We are proud to present the Panasonic Fax Advantage Program. It's an incredible service program that's full of exciting advantages!

Customer Satisfaction

In support of our one-year limited warranty* (parts and labor) on our current fax product line, Panasonic is proud to offer you the following service options during the limited warranty period:

- 1 If you mail-in or carry-in your fax unit to one of our Regional Servicenters, the product will be repaired and returned to you, or...
- 2 If you call our 1-800-HELPFAX toll-free number, you will receive a refurbished replacement product overnight or on the second business day (delivery depending on the time of your call.)

Support After The Sale

If you have a problem with your fax, just call our 1-800-HELPFAX toll-free number for friendly support and assistance. We have a highly-qualified team of experts who can diagnose, and most likely solve, your problem over the phone. Approximately 90% of our customers' problems are resolved with just a simple phone call.

The Fax Advantage Program covers the first year of purchase and works like this:

- 1 If you have a problem with your fax, call toll-free 1-800-HELPFAX.
- 2 Talk to one of our experienced technical experts to diagnose (and most likely solve) your problem over the phone.
- 3 Providing that you may be entitled to Panasonic's service under the terms and conditions of the limited warranty**, we will arrange for a reconditioned replacement unit to be



shipped to you overnight or second business day delivery, depending on the time of your call. The replacement unit will be completely refurbished, quality-tested by Panasonic technicians, and individually hand-inspected before it is shipped to you. You will keep the replacement unit and send your

original unit to us, along with a copy of your receipt.

4 This receipt *must be shipped back* with your original unit to Panasonic Company (as per instructions enclosed in your replacement unit's box).

Any unit that is replaced by Panasonic and *not* backed up by a proof of purchase by you will be subject to a minimum \$100.00 charge. Any unit that is replaced, but does not meet the terms and conditions of the limited warranty will be subject to additional charges, as per the program guidelines.

5 Once you receive your replacement unit, pack up your problem unit in the replacement unit's box. UPS will make 3 attempts within 10 days to pick-up your defective unit at no charge to you (should you be entitled to warranty service. If warranty conditions do not apply, you will be charged for all applicable shipping charges). *The product must be properly packaged in the same manner as the replacement unit, utilizing the packing materials provided.* You must make your unit available for UPS pick-up. If your unit is not available for UPS, you will be responsible for shipping unit back at your expense. Damage due to improper or inadequate packing will be charged back to your charge card as an out-of-warranty cost, as per the warranty stipulations (see back panel.)

Requirements:

6 You must give our technicians a valid credit card number. They will keep this number on file to cover any charges that are incurred by failure to send the problem product to Panasonic Company. If your problem unit is not eligible for warranty, you will be charged for the repair of the unit and for any shipping charges associated with this program. If you do not wish to pay out-of-warranty repair costs, you will be responsible for returning the replacement unit to Panasonic and for paying all shipping charges associated with this program including the overnight delivery of replacement product to you, shipment of problem unit to Panasonic, the replacement unit back to Panasonic and the return of your original unit back to you.

Acceptable credit cards:

Discover VISA
Master Card American Express (Optima)

Product that is not returned to Panasonic by 10 business days after shipment of the replacement product, will be charged to your account at Panasonic's Suggested Retail Price (see dealer for details).

Credit status will be verified prior to sending the replacement product.

Proof of Purchase must be included with the returned unit to verify warranty status.

Any parts and labor that are not covered by the limited warranty* will be charged as a non-warranty repair and billed at Panasonic's current rate for parts and labor.

*See back panel for one-year limited warranty.

**Replacement program excludes Puerto Rico and is subject to termination at any time without advance notice.



Matsushita Consumer Electronics Company, Division of Matsushita Electric Corporation of America

One Panasonic Way, Secaucus, New Jersey 07094

Panasonic Sales Company, Division of Matsushita Electric of Puerto Rico, Inc. ("PSC")

Ave. 65 de Infantería, Km. 9.5
San Gabriel Industrial Park, Carolina, Puerto Rico 00985

© Matsushita Electric Industrial Co. Ltd.
All rights reserved. Unauthorized copying and distribution is a violation of law